

TECHNICAL MANUAL

**Operator's Manual
for
WAREHOUSE CRANE
10,000 LB. CAPACITY, M469
WHEELED, DIESEL POWERED
NSN 3950-01-412-5345
(Grove Model AP 308T)**

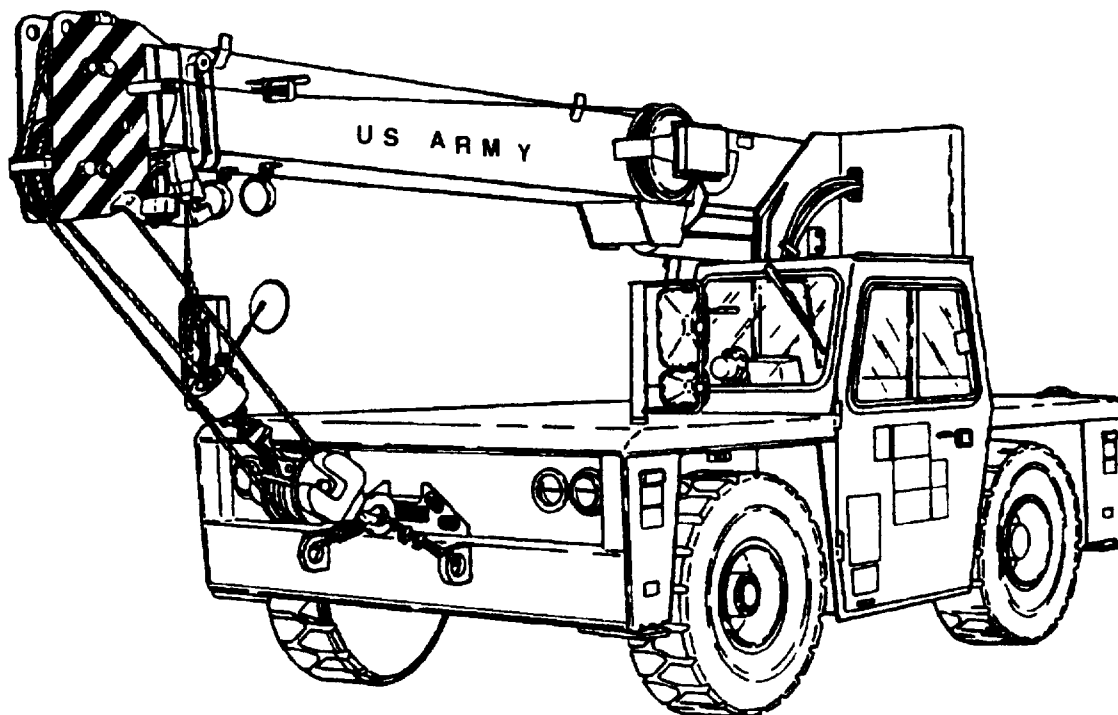

Approved for public release: Distribution is unlimited.

HEADQUARTERS, DEPARTMENT OF THE ARMY

JUNE 1997

WARNING

OPERATIONS ADJACENT TO OVERHEAD LINES ARE PROHIBITED UNLESS ONE OF THE FOLLOWING CONDITIONS ARE SATISFIED.

1	POWER HAS BEEN SHUT OFF AND POSITIVE MEANS TAKEN TO PREVENT LINES FROM BEING ENERGIZED.	
2	POSITION AND BLOCK EQUIPMENT INSURING NO PARTS, INCLUDING CABLE, CAN COME WITHIN THE FOLLOWING CLEARANCES	<u>VOLTAGE REQD CLEARANCE</u> UNDER 50 KV - 10 FEET 69 KV - 12 FEET 115-161 KV - 15 FEET 230-285 KV - 20 FEET 345 KV - 25 FEET 500 KV - 35 FEET

CHECK WITH YOUR LOCAL POWER SUPPLIER FOR CORRECT LINE VOLTAGE

NOTE

READ AND UNDERSTAND ALL OF THE SAFETY WARNINGS AND CAUTIONS CONTAINED IN SECTION 2 - SAFETY PRECAUTIONS BEFORE OPERATING THE CRANE, DIRECT ANY QUESTIONS THAT YOU MAY HAVE TO YOUR SUPERVISOR FOR CLARIFICATION.

Operator's Manual
for
WAREHOUSE CRANE
10,000 LB. CAPACITY, M469
WHEELED, DIESEL POWERED
NSN 3950-01-412-5345
(Grove Model AP 308T)

HEADQUARTERS,
DEPARTMENT OF THE ARMY
Washington, DC, 15 June 1997

REPORTING OF ERRORS

You can improve this manual. If you find any mistakes or if you know of a way to improve the procedures, please let us know. Mail your letter, DA Form 2028 (Recommended Changes to Publications and Blank Forms) or DA Form 2028-2 located in the back of this manual direct to: Commander, US Army Tank-automotive and Armaments Command, ATTN: AMSTA-IMOPIT, Warren MI 48397-5000. A reply will be furnished to you. You may also provide DA Form 2028-2 information to TACOM via datafax or e.mail.

TACOM's datafax number for AMSTA-IM-OPIT is: (810) 574-6323 e.mail address is: tacom-tech-pubs@cc.tacom.army.mil

Approved for public release: Distribution is unlimited.

TABLE OF CONTENTS

Page

	HOW TO USE THIS MANUAL	iii
SECTION 1	GENERAL	1-1
	Introduction	1-1
	List of Specifications	1-1
SECTION 2	SAFETY PRECAUTIONS	2-1
	General	2-1
	Travel Operation.....	2-7
	Craning Operation.....	2-8
	Wire Rope and Sheaves.....	2-13
	Controlled Free-Fall Hoist	2-17
	Electrical Hazards	2-18
	Personnel Platforms	2-23
	Cold Weather Operation	2-23
	Don't Forget	2-24
SECTION 3	PREPARATION FOR USE	3-1
	Summary	3-1
	Unpacking.....	3-1
	Checking Unpacked Equipment	3-1
	Deprocessing Unpacked Equipment	3-1
	Preliminary Servicing and Adjustment	3-1

TABLE OF CONTENTS - Continued

SECTION 4 PRINCIPLES OF OPERATION 4-1
 General 4-1
 Major Components and Systems 4-1

SECTION 5 OPERATING INSTRUCTIONS 5-1
 Controls and Indicators 5-1
 Preventive Maintenance Checks and Services (PMCS) 5-8
 Operating Procedures 5-23

SECTION 6 MAINTENANCE INSTRUCTIONS 6-1
 Lubrication Instructions 6-1
 Troubleshooting 6-12
 Installing Cable on the Hoist 6-29
 Cable Reeving 6-30
 Installing Wedge and Socket 6-31

APPENDIX A REFERENCES A-1

APPENDIX B COMPONENTS OF END ITEM AND BASIC ISSUE ITEMS LIST B-1

APPENDIX C ADDITIONAL AUTHORIZATION LIST C-1

APPENDIX D EXPENDABLE/DURABLE SUPPLIES AND MATERIALS LIST D-1

APPENDIX E LOAD CHART F-1

INDEX ALPHABETICAL INDEX INDEX-1

HOW TO USE THIS MANUAL

This manual is designed to help you operate and maintain the equipment. All task descriptions will take you step-by-step through the procedure. Don't take shortcuts. Before you begin any task, you should read through the complete procedure, make sure you know what needs to be done, then go back and follow the steps as written.

Pay particular attention to WARNINGS and CAUTIONS, as they contain information that will prevent injury to personnel or damage to equipment.

Use the alphabetical index at the back of the manual to find a topic not listed in the table of contents.

The definitions of WARNING, CAUTION, and NOTE as used in this manual apply as follows:

WARNING

A WARNING IS USED TO EMPHASIZE THAT IF AN OPERATION, PROCEDURE, OR PRACTICE IS NOT FOLLOWED EXACTLY, DEATH OR INJURY TO PERSONNEL MAY RESULT.

CAUTION

A CAUTION IS USED TO EMPHASIZE THAT IF AN OPERATION, PROCEDURE, OR PRACTICE IS NOT FOLLOWED EXACTLY, EQUIPMENT DAMAGE MAY RESULT.

NOTE

A note is used to emphasize an important procedure or condition.

DO NOT OVERLOAD

Weight of load should always be known before any attempt is made to lift it.

WARNING

DO NOT OPERATE THIS CRANE WITH A JIB (SWINGAWAY OR EXTENSION) TAKEN FROM ANOTHER CRANE OR WITH ONE ORDERED AND FIELD INSTALLED UNLESS THE PROPER JIB LOAD CHART HAS BEEN INSTALLED IN THE CRANE CAB.

WARRANTY

THERE ARE NO WARRANTIES, EXPRESS OR IMPLIED, MADE BY EITHER THE DISTRIBUTOR OR THE MANUFACTURER ON NEW GROVE EQUIPMENT, EXCEPT THE MANUFACTURER'S WARRANTY AGAINST DEFECTS, MATERIAL AND WORKMANSHIP SET OUT BELOW:

NEW EQUIPMENT WARRANTY

"The Manufacturer warrants each new product made by the Manufacturer to be free from defects in material and workmanship, its obligation and liability under this warranty being limited to replacing free of charge at its factory, any part proving defective under normal use and service within six (6) months from the date of initial sale, lease, or rental, providing the equipment is on record with the Manufacturer as being installed by the distributor. If the machine is not on record as being installed by the distributor, the Manufacturer will consider the date of shipment from the factory as the date of initial sale, lease, or rental. This warranty is in lieu of all other warranties, express or implied and the obligation and liability of the Manufacturer under this warranty shall not include any transportation or other charges or the cost of installation or any liability for direct, indirect, or consequential damages or delay resulting from the defect. Any operation beyond rated capacity or the improper use or application of the product or the substitution upon it of parts not approved by the Manufacturer shall void this warranty. This warranty covers only the products of Grove Manufacturing Company. The products of other Manufacturers are covered only by such warranties as are made by their Manufacturers."

THIS WARRANTY IS EXPRESSLY IN LIEU OF ANY OTHER WARRANTIES, EXPRESS OR IMPLIED, INCLUDING ANY IMPLIED WARRANTY OF MERCHANTABILITY OR FITNESS FOR A PARTICULAR PURPOSE, AND OF ANY OTHER OBLIGATIONS OR LIABILITY ON THE PART OF THE MANUFACTURER, AND GROVE MANUFACTURING COMPANY NEITHER ASSUMES NOR AUTHORIZES ANY OTHER PERSON TO ASSUME FOR IT ANY OTHER LIABILITY IN CONNECTION WITH SUCH EQUIPMENT.

NOTE

**The Cummins diesel engine is covered
by a separate warranty as described in
TM 10-3950-672-24.**

SECTION 1

GENERAL

1-1. INTRODUCTION.

This handbook provides information for the operator of the AP308T Grove 10K Warehouse Crane, M469.

The lift capacities are listed on the Load Chart in the cab.

The crane incorporates an all welded steel frame using a single reduction drive axle to provide front wheel drive. Rear axle steering is accomplished utilizing a hydraulic steer cylinder attached to the Grove fabricated rear axle. The engine is mounted at the rear of the crane and provides motive power through a three speed automatic transmission. The outriggers are oblique telescoping on both the front and rear of the crane.

The superstructure is capable of 360 degrees rotation in either direction. The boom is a 14 to 24 ft (4.2 to 7.3 m) two section full power boom and is trapezoidal in design.

NOTE

Throughout this manual, reference is made to left, right, front, and rear when describing locations. These reference locations are to be considered as those viewed from the operator's seat with the superstructure facing forward over the front of the carrier frame.

1-2. LIST OF SPECIFICATIONS.

GENERAL.

Model AP308T
 Rated Capacity See Load Chart in cab
 Drive 2 wheel front
 Gross Weight See Lifting and Transportation decal in cab

DIMENSIONS.

NOTE

Dimensions listed are with all components fully retracted.

Overall Crane Length221.0 in. (561.3 cm)
 Overall Crane Width84.0 in. (213.3 cm)
 Overall Crane Height92.90 in (235.9 cm)
 Track Width72.0 in. (182.8 cm)
 Tailswing.....42.0 in. (106.6 cm)
 Tail Sweep.....205.60 in. (522.2 cm)

DIMENSIONS. (continued)

Turning Radius 183.38 in. (465.7 cm)
 Wheel Base 84.0 in. (213.3 cm)

CAPACITIES.

Fuel Tank
 (Total Capacity) 35.0 gal. (132.4 L)
 (Gauge Level Capacity) 30.0 gal. (113.5 L)
 Hydraulic Tank
 (Total Capacity) 35.0 gal. (132.4 L)
 (Gauge Level Capacity) 30.0 gal. (113.5 L)
 Coolant System 24.5 qt (23.1 L)
 Engine Lubrication System 11.5 qt (10.8 L)
 Hoist
 Grove H012 2.0 qt (1.8 L)
 Gear Reducer 1 pt (0.47 L)
 Differential 14.0 pt (6.5 L)
 Transmission (Gearbox)
 (Ford) (After partial drain) 5 qt (4.7 L) shallow pan or
 6 qt (5.6 L) deep pan
 (Ford) (After complete drain) 11.75 qt (11.2 L)

ENGINE.

Make and Model Cummins 4B3.9 L
 Type 4 Cylinder Diesel O.H.V., Naturally-aspirated
 Bore 4.02 in. (102.1 mm)
 Stroke 4.72 in. (119.8 mm)
 Displacement 239 cu in. (3916.4 cm³)
 Horsepower (Net) 80
 Governed RPM 2400
 Torque (Net) 184 lb ft (25.4 kgm) @ 1500 RPM
 Combustion System Direct Injection
 Fuel Injection Pump Lucas CAV DPA Mechanically-governed

FIRE EXTINGUISHER.

Manufacturer Kidde
 Type Dry Chemical
 Rating 10 BC
 Weight 2.75 lb (1.25 kg)

TRANSMISSION.

Manufacturer Ford
 Model C-6
 Speeds 3 forward and 1 reverse

TRANSMISSION. (continued)

Gear Ratios
 Low (1st) 2.46:1
 Int (2nd) 1.46:1
 Direct (3rd) ` 1.00:1
 Reverse..... 2.175:1
 Stall Ratio..... 1.89:1
 Filter Internal

REAR (STEER) AXLE.

Manufacturer Grove
 Type Rigid mounted, wide track

FRONT (DRIVE) AXLE.

Type Single Reduction
 Ratio..... 7.8:1

WHEELS AND TIRES.

Lugs - Front Axle 6
 Rear Axle 6
 Torque 300 lb ft (41.4 kgm)
 Tire Size 10.00 x 15 H
 Ply 16 PR
 Pressure Refer to Tire Inflation Table in Appendix E (Sheet 9)

BRAKES.

Service.

Type Hydraulic w/ Manually-adjustable Brake Shoes

Parking.

Type Brake and Shoe Bolted to Transmission

STEERING PUMP.

Manufacturer Parker-Hannifan
 Type Gear
 Output 6 gpm (22.7 lpm)
 Displacement 0.941 cu in. (15.42 cu cm) per rev.

STEERING CONTROL VALVE.

Manufacturer Charr-Lynn
 Displacement 14.8 cu in. (242.5 cu cm) per rev.
 Capacity 6 gpm (22.7 lpm)

HYDRAULIC PUMP.

Manufacturer Commercial Shearing
 Type Gear
 Sections 2
 GPM 27.4 gpm (103.7 lpm) @ 2400 RPM and
 18.9 gpm (71.5 lpm) @ 2400 RPM

SWING MOTOR.

Manufacturer Eaton
 Type Orbit
 Displacement 6.2 cu in. (101.5 cu cm) per rev.

SWING GEAR REDUCER.

Manufacturer Grove
 Type Gear Reduction
 Reduction Ratio 27.98:1

BOOM.

Elevation -0 to + 70 degrees
 Length
 Two Section 14-24 ft (4.2-7.3 m)
 Power Full

HOIST.

Manufacturer Grove
 Drum Dimension
 Diameter 9.625 in (24.4 cm)
 Length 9.0 in (22.8 cm)
 Cable Size 9/16-inch (14 mm)
 Maximum Capacity 181 ft (55.2 m)
 Stowage 13 5 ft (41.1 m)
 Permissible Line Pull Refer to the Line Pull and Reeving
 Information Chart in cab

COUNTERWEIGHT.

Type Welded to turntable

OUTRIGGERS.

Type Oblique telescoping removable beams
 Length
 Extended 5 ft 5 (1.67 m)
 Retracted 3 ft 5.5 in. (1.08 m)

HYDRAULIC SWIVEL.

Manufacturer Grove
Ports 6

ELECTRICAL SWIVEL.

Slip Rings 10

ELECTRICAL SYSTEM.

Type Single wire ground return (chassis)
System Voltage..... 12 VDC negative - ground
Batteries
 Number 1
 Manufacturer East Penn Mfg.
 Model 724MF
 Cold Cranking Hours (CCH)
 Charge Indicator Use Voltage Tester
Alternator
 Manufacturer Prestolite
 Rating 65 amperes

CAB HEATER.

Type Hot Water

TRANSPORTATION AND LIFTING DATA AP308

BOOM
1751 LBS.

TURNTABLE
3350 LBS.

SUPERSTRUCTURE
9577 LBS.

CARRIER
14985 LBS.

FITTINGS	NO. / UNIT	TOTAL UNIT						CAR-RIER		S/S	T/T	BOOM	FITTING CAPACITY (TONS)					
		LIFT	TOW	TIEDOWN	LIFT	TOW	TIEDOWN	LIFT	LIFT				LIFT	LIFT	TOW	TIE DOWN		
																FORE & AFT	SIDE	DOWN
A	2	X	X	X	X	X	X						11	35	35	4	11	
B	2	X	X	X	X	X	X						11	35	35	4	11	
C	1							X			X		8					
D	1							X			X		8					
E	2							X	X		X		6					

1. LIFTING OF ENTIRE CRANE OR MAJOR CRANE ASSEMBLIES MUST BE ACCOMPLISHED BY UTILIZING SPECIFIC FITTINGS INDICATED ON ABOVE CHART. USE OF FITTINGS FOR PURPOSES OTHER THAN THOSE DESIGNATED ON CHART IS PROHIBITED. FITTING CAPACITIES ARE MAXIMUM ALLOWABLE LOADS PER INDIVIDUAL FITTING.

2. RIGGING PERSONNEL SHALL BE RESPONSIBLE FOR PROPER SELECTION AND PLACEMENT OF ALL SLINGS AND LOAD HANDLING DEVICES.

3. WEIGHTS DO NOT INCLUDE BOOM EXTENSION AND/OR JIB.

TOTAL UNIT
1805 LBS.

SECTION 2

SAFETY PRECAUTIONS

2-1. GENERAL.

It is impossible to compile a list of safety precautions covering all situations. However, there are basic safety precautions that **MUST** be followed during your daily routine. Safety is **YOUR PRIME RESPONSIBILITY**, since any piece of equipment is only as safe **AS THE PERSON AT THE CONTROLS**.

With this thought in mind, this information has been provided to assist you, the operator, in promoting a safe working atmosphere for yourself and those around you. It is not meant to cover every conceivable circumstance which could arise. It is intended to present basic safety precautions that should be followed in daily operation.

Because you, the operator, are the only part of the crane that can think and reason, your responsibility is not lessened by the addition of operational aids or warning devices. Indeed, you must guard against acquiring a false sense of security when using them. They are there to assist, **NOT** direct the operation. Operational aids or warning devices can be mechanical, electrical, electronic, or a combination thereof. They are subject to failure or misuse.

You, the operator, are the only one who can be relied upon to assure the safety of yourself and those around you. Be a **PROFESSIONAL** and follow the **RULES** of safety.

REMEMBER, failure to follow just one safety precaution can cause that accident to people or equipment.

You are responsible for the safety of yourself and those around you.

Ensure you and those working with you are aware of any special dangers where you are operating the crane. Be especially careful of dangerous ground and objects; including buildings, near the crane.

Be aware at all times that you are responsible for the safety of yourself, your coworkers, the crane and everything around it. Make certain the crane is properly maintained, and then pay attention to winds, boom deflections, rope sway, and any unusual things, which you, as a crane operator, may notice which would not be important to others.

Know and abide by the basic safety rules.

Read and understand the Operator's Manual before entering the cab.

Follow directions on all placards. Know what they mean and follow their instructions.

Be prepared for the work day.

WARNING

Operators must be thoroughly familiar with safe crane operating practices and have a complete understanding of all operation and maintenance instructions provided. Operators should be physically fit and thoroughly trained, with related experience, not be easily excitable, not be subject to epileptic seizures, and not be using any drug that could impair physical, visual, or mental reactions or capabilities.

Wear the proper clothing for the job. Wear personnel protective equipment as required by local or job regulations.

Perform all Preventive Maintenance Services and Checks (PMCS). Refer to Chapter 5. Ensure that routine maintenance and lubrication are being dutifully performed. Don't operate a damaged or poorly maintained crane. You risk lives when operating faulty machinery, including your own.

Know the area in which you are working. Familiarize yourself with work site obstructions and other potential hazards in the area.

Use caution when in the vicinity of overhanging banks or edges.

Keep your shoes clean. Before entering the cab, clean any mud or grease from your shoes. This will reduce the possibility of your foot slipping off a control pedal, possibly resulting in an accident.

Since certain shoe sole materials are more slip resistant than others, all operating and service personnel should wear footwear with high slip resistant sole material.

Avoid a dirty or greasy crane. Keep the cab, deck, and foot and hand holds free of mud and grease for operator safety. Dirty equipment fails rapidly and makes good maintenance difficult.

Observe and heed possible pinch points while performing maintenance or other work.

Check for WARNING tags placed on the crane. If found, refuse to operate the crane until repairs are made and WARNING tags are removed by authorized personnel.

Before performing maintenance, disconnect the battery, remove the ignition key, and place WARNING SIGNS in the cab.

BEFORE performing maintenance on the crane, remove all weight from outrigger jack cylinders, and lower attachments to the ground or place them on suitable blocking.

Pressurized air and hydraulic oil can cause serious injury. Be certain all lines, components, and fittings are tight and serviceable. Use a piece of cardboard or wood to search for suspected leaks in hydraulic systems and soapy water to search for leaks in pneumatic systems.

Always replace the guards or other safety devices which may have been removed during crane repair or adjustment.

Have an approved fire extinguisher available and know how to use it. Inspect as required to ensure it is fully charged and operable.

Remove rings, bracelets, wristwatches, and neck chains before working on any vehicle. Jewelry can catch on equipment and cause injury, or may short across an electrical circuit and cause severe burns or electrical shock.

Lead-acid battery gases can explode. Do not smoke, have open flames, or make sparks around a battery, especially if caps are off. If a battery is gassing, it can explode and cause injury to personnel.

- Ventilate when charging or using in an enclosed space.
- Wear safety goggles and acid-proof gloves when battery cover must be removed or when adding electrolyte.
- Avoid electrolyte contact with skin, eyes, or clothing. If battery electrolyte spills, take immediate action to stop burning effects:
 - External: Immediately flush with cold running water to remove all acid.
 - Eyes: Flush with cold water for at least 15 minutes. Seek immediate medical attention.
 - Internal: Drink large amounts of water or milk. Follow with milk of magnesia, beaten egg, or vegetable oil. Seek immediate medical attention.
 - Clothing or Vehicle: Wash at once with cold water. Neutralize with baking soda or household ammonia solution.

Wear safety glasses or goggles when checking batteries. Always check electrolyte level with engine stopped. Do not smoke or use exposed flame when checking battery; explosive gases are present and severe injury to personnel can result.

Disconnect battery negative cable at post prior to performing maintenance in immediate battery area or working on electrical system. Such disconnections prevent electrical shock to personnel or equipment.

Battery acid (electrolyte) is extremely harmful. Always wear safety goggles and rubber gloves, and do not smoke when performing maintenance on batteries. Injury will result if acid contacts skin or eyes. Wear rubber apron to prevent clothing being damaged.

Remove all jewelry such as rings, dog tags, bracelets, etc. If jewelry contacts battery terminal, a direct short may result in instant heating of tools, damage to equipment, and injury or death to personnel.

Check battery condition only with proper test equipment. Batteries shall not be charged except in an open, well ventilated area free of flame, smoking, sparks, and fire.

Before charging a battery, consult the battery manufacturer's instructions.

Follow standard safety precautions when refueling. FUEL IT SAFELY.

Do not remove the radiator cap when the engine is hot; steam and hot coolant can escape and burn personnel.

Use extreme care when removing the radiator pressure cap. Sudden release of pressure can cause a steam flash which could seriously injure personnel. Slowly loosen cap to the first stop to relieve pressure before removing cap completely. After use, securely tighten cap.

Use a clean, thick waste cloth or like material to remove the cap. Avoid using gloves. If hot water soaks through gloves, personnel could be burned.

Do not drain engine oil while engine is hot. Severe injury to personnel may result.

BURN HAZARD

Allow engine to cool before performing maintenance on the muffler, exhaust pipe, exhaust manifold, or turbocharger. If necessary, use insulated pads and gloves.

Do not touch hot exhaust system with bare hands; injury to personnel will result.

EXHAUST GASES CAN KILL

Brain damage or death can result from heavy exposure. Precautions must be followed to ensure crew safety when personnel heater, main, or auxiliary engine of any vehicle is operated for any purpose.

- Do not operate vehicle engine in enclosed areas.
- Do not idle vehicle engine with vehicle windows closed.
- Be alert at all times for exhaust odors.
- Be alert for exhaust poisoning symptoms. They are:
 - Headache
 - Dizziness
 - Sleepiness
 - Loss of muscular control
- If you see another person with exhaust poisoning symptoms:
 - Remove person from area
 - Expose to open air

- Keep person warm
- Do not permit physical exercise
- Administer artificial respiration, if necessary*
- Seek immediate medical attention

* For artificial respiration, refer to FM 21-11.

- * BE AWARE, the field protective mask for nuclear-biological-chemical (NBC) protection will not protect you from carbon monoxide poisoning.

THE BEST DEFENSE AGAINST EXHAUST POISONING IS ADEQUATE VENTILATION.

High pressure hydraulics operate this equipment. Refer to TM 10-3950-672-24-1 for hydraulic oil pressure. Never disconnect any hydraulic line or fitting without first dropping pressure to zero. A high pressure oil stream can pierce body and cause severe injury to personnel.

Diesel or hydraulic fluid under pressure can penetrate skin or damage eyes. Fluid leaks under pressure may not be visible. Use a piece of cardboard or wood to find leaks, but do not use a bare hand. Wear safety goggles for protection. If fluid enters skin or eye, get immediate medical attention.

Do not move under any hydraulically controlled implement when making adjustment or repairs to hydraulic system. Lower implement and work from above. If implement must be raised for access, always block to support. If implement drops, injury to personnel can result.

FALLING EQUIPMENT HAZARD

Never crawl under equipment when performing maintenance unless equipment is securely blocked. Equipment may fall and cause serious injury or death to personnel.

Keep clear of equipment when equipment is being raised or lowered. Equipment may fall and cause serious injury or death to personnel.

Do not work on any item supported only by lift jacks or hoist. Always use blocks or proper stands to support the item prior to any work. Equipment may fall and cause injury or death to personnel.

Do not allow heavy components to swing while hanging by lifting device. Equipment may strike personnel and cause injury.

Exercise extreme caution when working near a cable or chain under tension. A snapped cable, shifting or swinging load may result in injury or death to personnel.

All personnel must stand clear during lifting operations. A swinging or shifting load may cause injury or death to personnel.

Unless authorized and approved by Grove Manufacturing Company, do not make any modifications, alterations, or changes to a crane which could in any way affect its original design. Such action invalidates all warranties and capacity charts, and makes the owner/user liable for any resultant accidents.

Keep your fingers away from potentially hazardous areas.

Use cleaning solutions that are non-flammable and approved for the work being performed.

Always perform a function check after repairs have been made to ensure proper operation.

Load tests should be performed when structural or lifting members are involved.

Do not store flammable materials on the crane at any time.

Never get off or on a moving crane.

When getting on or off a stationary crane, use both hands and use the handrails and steps provided.

Allow No one other than the operator to be on the crane while the crane is functioning or moving.

Check the tire pressure daily. When inflating or adding air to the tires, use a tire cage and clip on inflator. Use an extension hose which will permit standing behind the tire tread when inflating.

When shutting down the crane adhere to the following:

- engage the parking brakes
- lower the boom and the load
- place the controls in neutral
- chock the wheels
- ensure the swing lock is engaged.

Don't touch metal surfaces that could freeze you to them.

Dry cleaning solvent (P-D-680) is TOXIC and flammable. Wear protective goggles and gloves; use only in well-ventilated area; avoid contact with skin, eyes, and clothes, and do not breathe vapors. Keep away from heat or flame. Never smoke when using solvent; the flashpoint for type I dry cleaning solvent is 100° F (38°C) and for type II is 138°F (50° C). Failure to do so may result in injury or death to personnel.

If personnel become dizzy while using cleaning solvent, immediately get fresh air and medical help. If solvent contacts skin or clothes, flush with cold water. If solvent contacts eyes, immediately flush eyes with water and get immediate medical attention.

CAUTION

Proper lubrication is a requirement in any heavy equipment operation. Follow the factory recommendations regarding the lubrication time intervals and types of lubricants used. Adjust time intervals accordingly, when working under severe conditions.

When adding oil to the hydraulic system, follow the manufacturer's recommendations. Mixing the wrong fluids could destroy seals, causing machine failure.

When performing maintenance, refer to the appropriate manual for instructions. Consult the factory if there are any questions regarding procedures or specifications.

Do not attempt repairs you do not understand! Never exceed the manufacturer's recommended relief valve pressure settings.

Maintain battery electrolyte at the proper level. Check the state of charge indicator with a flashlight.

Keep the crane properly maintained and adjusted at all times. Shut down the crane while making repairs or adjustments.

Keep brakes properly adjusted. Keep brake linings free of oil and grease. Do not over lubricate the bearings or brake anchor pins. Refer to the Preventive Maintenance Checks and Services (PMCS), Section 5.

Inspect the tires for nicks and cuts, imbedded stones, and abnormal wear. Ensure all lug nuts are properly torqued.

In freezing weather, park the crane in an area where it cannot become frozen to the ground.

The drive line can be damaged when attempting to free a frozen crane.

2-2. TRAVEL OPERATION.

WARNING

Check load limit of bridges. Before traveling across bridges, ensure they will carry a load greater than the crane's weight.

Watch clearances when traveling. Do not take a chance of running into overhead or side obstructions.

Never back up without the aid of a signalman to verify the area behind the crane is clear of obstructions and/or personnel.

When traveling, the boom should be completely retracted, lowered, and stowed in its travel position.

Secure the hook block and other items before moving the crane.

When traveling, keep the lights on, use traffic warning flags and signs, and use front and rear flag vehicles. Check state and local restrictions and regulations.

Drive carefully and avoid speeding.

Before traveling a crane, check suitability of proposed route with regard to crane height, width, and length.

Secure the turntable before moving crane, use the swing lock.

Stay alert at the wheel.

When parking on a grade, apply the parking brake and chock the wheels.

CAUTION

When moving in tight quarters, post a look-out to help guard against collisions or bumping structures.

2-3. CRANING OPERATION.

WARNING

Check crane stability before lifting loads. Ensure the outriggers (or tires if lifting on rubber) are firmly positioned on solid surfaces. Ensure the crane is level, brakes are set, and the load is properly rigged and attached to the hook. Lift the load slightly off the ground and recheck the stability before proceeding with the lift. Determine the weight of the load before you attempt the lift. Check the load chart against the weight of the load.

Most accidents involving mobile hydraulic cranes are caused by the following:

- crane out of level
- bad surface conditions
- outriggers used improperly or not used at all
- inadequate blocking under outrigger floats
- improper crane operation.

After the crane has been properly set-up, make a dry run before making the first lift. Become familiar with all factors peculiar to the job site. Know what moves to make BEFORE attaching the first load. Plan ahead.

Unless lifting within On Rubber capacities, the outriggers must be fully extended to provide maximum leveling of the crane. Remove all weight from tires before lifting on outriggers.

Use adequate cribbing under outrigger floats to distribute weight over a greater area. Check frequently for settling.

Use the sight level bubble indicator to ensure crane leveling.

Use the load line to determine the levelness of the crane. It should always lie in the center of the boom. Check at two points 90 degrees apart.

Be sure the hoist line is vertical before starting the lift. Don't subject the crane to side loadings.

Measure the load radius before making lifts and stay within approved lifting areas. Check your load chart!

The importance of properly leveling a crane cannot be overstressed. A crane only slightly out of-level can quickly encounter a tipping condition.

Barricade the area around which the crane is working.

Don't interfere with the proper functioning of operational aids or warning devices. Monitor them regularly and see they get the proper care.

Always refer to the capacity on the load chart in the cab BEFORE making any lift. Position the hoist line to the radius required then lift the load. Stay within the approved work area for the load being lifted.

Remember all rigging equipment must be considered as part of the load. Lifting capacities vary with working area. Permissible working areas are posted in the crane cab. When swinging from one working area to another, ensure load chart capacities are not exceeded. Know your crane!

Operate the engine at or near governed RPM during performance of all crane operations.

Do not exceed crane rating. Do not rely on the crane tipping stability to determine the maximum lifting capacity. Do not exceed the capacities shown on the load chart in the cab. REMEMBER: ALL LIFTING DEVICES (HEADACHE BALL, BLOCK, JIB, ETC.) ARE PART OF THE LOAD.

Always check the capacity of the crane as shown on the load chart before making any lifts.

Know the weight of all loads before you attempt a lift. Ensure the load to be lifted is within the rated lifting capacity of the crane.

Always keep the load as near to the crane and as close to the ground as possible.

NEVER exceed the rated lift capacity shown on the load chart. Always check the load chart to ensure the load to be lifted at the desired radius is within the rated capacity of the crane.

NEVER use the crane stability to determine capacity. It may be too late when you find out.

Multiple crane lifts are not recommended. The use of more than one crane to make a lift requires the ultimate in equipment, engineering, operating skill, and lift coordination.

BUT, if it is necessary to perform a multi-crane lift, the operator shall be responsible for assuring that the following minimum safety precautions are taken.

1. Secure the services of a qualified engineer to direct operation.
2. Use one signal person and be sure he is qualified.

3. Coordinate lifting plans with the operator, engineer, and signal person prior to beginning the lift.
4. Use cranes and rigging of equal capabilities and use the same boom length. Be , , certain cranes are of adequate lifting capacity.
5. Use outriggers on cranes so equipped.
6. Calculate the amount of weight to be lifted by each crane and attach slings at the correct points for proper weight distribution.
7. Lift only from a stationary position DO NOT TRAVEL.
8. If possible, provide approved radio equipment for voice communication between all parties engaged in the lift.
9. Ensure the load lines are directly over the attach points to avoid side loading the cranes.

Always use enough parts-of-line to accommodate heavy lifts. Provide a safety allowance and reeve more parts of line, rather than fewer parts, than you need. Refer to the values on the load capacity chart for the line weight ratios.

Watch the tail-swing of the revolving superstructure, especially if there are people or obstacles in the area.

Always make daily inspections of the wire rope and replace worn, rusty, or frayed ropes.

Always place the load on the ground when lubricating or adjusting.

A qualified signalman should be available at all times and especially when;

- working in vicinity of power lines
- the crane operator cannot clearly see the load at all times
- moving the crane in an area or direction in which the operator cannot clearly see the path of travel.

At all times use standardized hand signals previously agreed on and completely understood by the operator.

If communication with the signalman is lost, crane movement must be stopped until contact is regained.

Watch the load at all times. Watch the signalman and/or load while it is moving. In case you must look in another direction, stop the operation immediately.

Use only one qualified signalman whenever vision is obscured and follow only his directions.

BUT...obey a signal to stop from anyone.

KEEP THE BOOM SHORT. Swinging loads with a long line can create an unstable condition and possible structural failure of the boom.

Sound a warning before moving the crane or when approaching personnel.

Always move toward the load and move slowly. Use a tagline to control the load.

Stay clear of the sheave wheels, holes, and lattice work in telescoping booms and other potentially dangerous areas whenever the crane is in operation.

Pinch points are impossible to eliminate. Keep all portions of your body away from cable drums, sheaves, pulleys, lift cylinders, and other moving parts of the crane. Be extremely careful when performing maintenance on the crane.

Use extreme caution when lifting with more than one hoist.

Do not strike any obstruction with the boom. If the boom should accidentally contact an object; stop immediately. Inspect the boom. Remove the crane from service if the boom is damaged.

Never push or pull with a crane boom.

Do not add to the counterweight to increase capacity.

When lifting loads, lift slowly and proceed with caution.

Maintaining a steady tension may free the load without shock loading the crane.

Cranes are designed and rated to handle freely suspended loads. Do not pull post, piling, or submerged articles that may have a heavy accumulation of mud, silt, or sand.

When lifting loads, the crane will lean toward the boom and the load will swing out, increasing load radius. Ensure the load capacity chart is not exceeded when this happens.

Check the swing brake. Make certain the swing brake operates correctly. Unexpected free swinging of a boom can be dangerous.

Wind and other factors such as boom length, boom angle, size and weight of load being lifted, etc. can affect crane stability and crane structures. Practical working loads for each particular job and lift shall be established by the user depending upon conditions that exist at the time a lift is being made. Appropriate capacity reductions shall be made whenever conditions indicate the possibility that a loss of crane stability or structural damage could occur. Be extremely cautious if wind velocity approaches 20 miles per hour.

Exercise caution when swinging loads.

Never swing or lower the boom into the carrier cab.

Stop the hook block from swinging when unhooking a load.

Swinging rapidly can cause the load to swing out and increase the load radius. Swing the load slowly. Swing with caution and keep the load lines vertical.

Operate the crane only from the crane operator's seat. Operating from any other position, such as reaching in a window, constitutes a safety hazard.

Never operate the crane with less than two wraps of rope on the hoist drum.

Check the hoist brake by raising the load a few inches and holding it there. Be sure the hoist brake is working correctly before continuing the lift. When using a controlled free-fall hoist, slowly return the hoist to normal lowering speed before stopping the descent of a load. Quick stops could cause the machine to fail. Also refer to CONTROLLED FREE-FALL HOIST information in this section.

Never pull sideways with the boom. Booms and swing systems are not designed to side pull and may be damaged if subjected to excessive side loading. Booms are designed for lifting only freely suspended loads.

NEVER permit anyone to ride loads, slings, hooks, etc., for any reason.

Look before swinging your crane. Even though the original set-up may have been checked, situations do change.

Never stand or work on or near the superstructure while the crane is moving or swinging.

Keep everyone away from suspended loads. Allow no one to walk under a load. Ensure that all slings, ties, and hooks are correctly placed and secured before raising or lowering the load.

Use tag lines, as appropriate, for positioning and restraining loads. Check the load slings before lifting.

Be sure everyone is clear of the crane and work area before making any lifts.

Check all braking and holding devices before operation. Perform an operational check of all braking (wheel and swing) and safety holding devices before starting any crane or traveling operations.

Be sure the load is well secured and attached to the hook with rigging of proper size and in good condition.

Allow no one to ride on the crane, carrier deck, engine compartment, etc.

Tag line personnel must guide the load from the ground.

Use only slings or other rigging devices rated for the job and use them properly. Never wrap the hoist cable around a load.

Check all tackle, hardware, and slings before use. Refuse to use faulty equipment.

Never work the crane when darkness, fog, or other visibility restrictions make such operations unsafe.

Exercise extreme caution when picking and carrying a load. Never pick and carry a load with a crane that is not authorized for such operation.

When performing pick and carry operations or operating on sloping ground, carry loads much less than the rated capacity. Keep the load low, carry the load uphill from the crane, swing only to keep the load uphill, and always place the loads on the high side.

When traveling with a load, the boom should be carried in line with the direction of motion.

Report any crane damage immediately.

Check all pin connections, bolts, latches, locks, braking and restraining devices, and operational aids before operation. Perform a visual inspection and replace/tighten any damaged or loose devices prior to initiating any crane or traveling operations.

Never leave the crane with a load suspended. Should it become necessary to leave the crane, lower the load to the ground and stop the engine before leaving the cab.

Be alert-stay alert.

Long cantilever booms can create a tipping condition when in an extended and lowered position. Retract the boom proportionally with reference to the capacity of the applicable load chart.

Never swing over personnel, regardless of whether load is suspended from or attached to the boom.

2-4. WIRE ROPE AND SHEAVES.

The following information is taken from a National Consensus Standard as referenced by Federal Government Agencies.

WARNING

Wire rope can become frayed or contain broken wires. Wear heavy leather-palmed work gloves when handling wire rope. Frayed or broken wires can injure hands.

Never let moving wire rope slide through hands, even when wearing gloves. A broken wire could cut through glove and cut hand.

All wire rope will eventually deteriorate to a point where it is no longer useable. Wire rope shall be taken out of service when any of the following conditions exist:

1. In running ropes, six randomly distributed broken wires in one lay or three broken wires in one strand in one lay.
2. Wear of one-third the original diameter of outside individual wires. Kinking, crushing, bird caging, or any other damage resulting in distortion of the rope structure.
3. Evidence of any heat damage from any cause.

4. Reductions from nominal diameter of more than
 - 1/64-inch for diameters up to and including 5/16-inch
 - 1/32-inch for diameters 3/8 and 1/2-inch inclusive
 - 3/64-inch for diameters 9/16 to 3/4-inch inclusive
 - 1/16-inch for diameters 7/8 to 1-1/8 inches inclusive
 - 3/32-inch for diameters 1-1/4 to 1-1/2 inches inclusive.
5. In standing ropes, more than two broken wires in one lay in sections beyond end connections or more than one broken wire at an end connection.

Refuse to work with worn or damaged wire rope.

Demand to see the rope inspection record required by law and inspect the wire rope yourself.

Don't take another person's word.

Never handle wire rope with bare hands.

Inspect the boom nose and hook block sheaves for wear. Damaged sheaves cause rapid deterioration of wire rope.

Use the wire rope that is specified by the manufacturer.

LIFT ONE LOAD AT A TIME. Do not lift two or more separately rigged loads at one time, even if the loads are within the rated crane capacity.

USE ENOUGH PARTS OF LINE FOR HEAVY LIFTS AND CHECK ALL LINES, SLINGS, AND CHAINS FOR CORRECT ATTACHMENT. To obtain maximum lifting capacities the hook block must be set up with enough parts of line **NO LESS THAN TWO WRAPS** of wire rope should remain on the hoist drum. When slings, ties, hooks, etc., are used, make certain they are correctly positioned and secured before raising or lowering the loads.

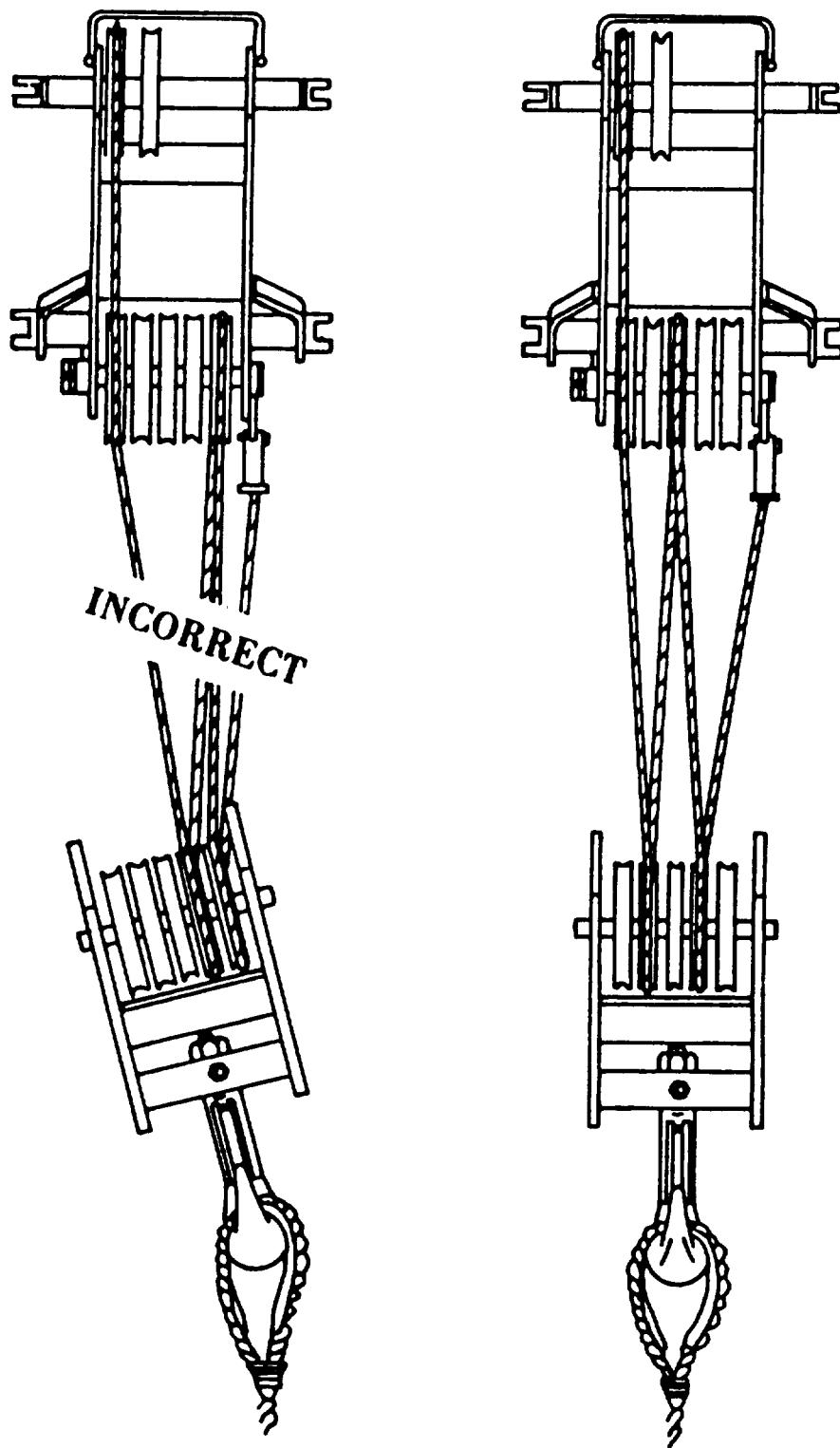

Ensure hoist cable (wire rope) is properly routed.

Two-blocking **MUST BE AVOIDED**, to prevent damage to your crane and to avoid creating a safety hazard. Two-blocking exists whenever the load block, headache ball, rigging, etc. come into physical contact with the boom, boom nose, sheave, jib, etc. Two-blocking can cause hoist lines (wire rope) rigging, reeving, and other components to become highly stressed and overloaded in which case the wire rope may fail allowing the load, block, etc. to free fall.

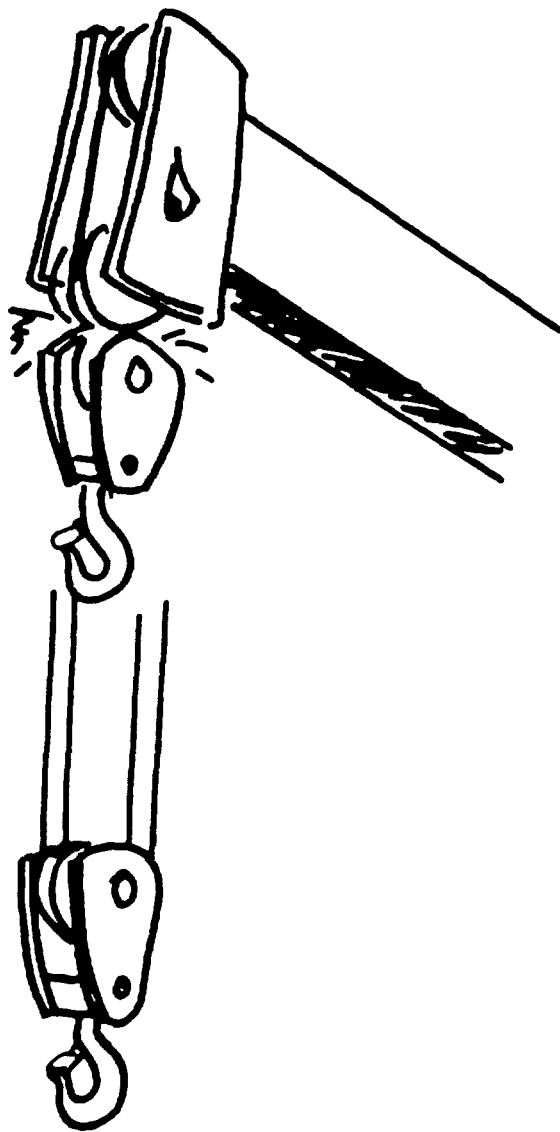

Your crane is equipped with an antitwo-block warning system. If the system has been damaged, removed from the crane, or a malfunction is suspected, refuse to operate the crane if the warning system is not installed and operating satisfactorily.

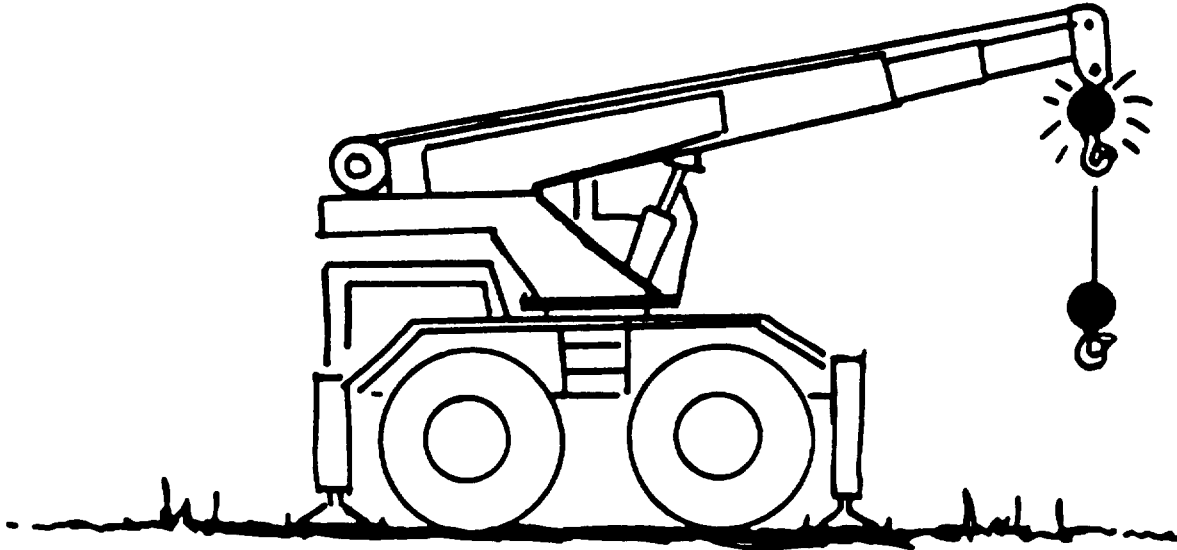

Caution must be used when lowering or extending the boom let out cable simultaneously to prevent two-blocking the boom nose and hook block. The closer the load is carried to the boom nose the more important it becomes to simultaneously let out cable as the boom is lowered. Keep the hook block, etc. at least 12 in. (30.48 cm) away from the boom nose at all times.

2-5. CONTROLLED FREE-FALL HOIST.

When using your crane during controlled free-fall hoisting operations, the following recommendations are offered:

WARNING

Exercise caution when using (optional) controlled free-fall hoists smooth and gradual snubbing of load is necessary to avoid high shock loads.

Use single-part (line) reeving only.

Fully extend and set the outriggers.

Ensure the crane is level and on a firm supporting surface.

Use main boom whenever feasible.

Reduce load values to 30% of the crane's rated load values or 50% of the permissible line pull values as indicated on the crane load capacity chart or the hoist manufacturer's maximum allowable rating, whichever is less.

2-6. ELECTRICAL HAZARDS.

Read and abide by this WARNING placard posted on the crane.

WARNING

ELECTROCUTION HAZARD
TO PREVENT DEATH OR SERIOUS BODILY INJURY

NEVER OPERATE THIS CRANE WITHIN ANY DISTANCE OF A POWER SOURCE OR POWER LINE WITHOUT FIRST NOTIFYING THE POWER OR UTILITY COMPANY.

NEVER OPERATE CRANE, ANY PART THEREOF OR LOAD WITHIN 20 FEET OF ANY ELECTRICAL POWER LINE OR POWER SOURCE OR SUCH DISTANCE AS IS SPECIFIED OR REQUIRED BY LOCAL OR OTHER APPLICABLE SAFETY CODES OR REGULATIONS.

NEVER OPERATE CRANE WITHOUT CONSULTING LOCAL OR OTHER APPLICABLE SAFETY CODES OR REGULATIONS.

NEVER OPERATE, SERVICE, OR MAINTAIN THIS CRANE WITHOUT PROPER INSTRUCTIONS. REMEMBER, IT IS THE EMPLOYER'S RESPONSIBILITY TO IMPLEMENT THE ABOVE AND TO PROVIDE ALL SAFETY DEVICES OR MEANS THAT MAY BE NECESSARY OR REQUIRED FOR ANY USE, OPERATION, SET-UP, OR SERVICE.

NEVER HANDLE PERSONNEL WITH THIS CRANE WITHOUT WRITTEN APPROVAL FROM GROVE MANUFACTURING COMPANY.

MAKE SAFETY FIRST--NOT LAST!!! **READ YOUR OPERATOR'S HANDBOOK!**

NOTE DO NOT REMOVE THIS SIGN OR OPERATOR'S MANUAL FROM THIS CRANE.

GROVE MANUFACTURING COMPANY

Division of K-000, Inc.
KIDDE Shady Grove PA 17266

WARNING

Crane operation is extremely dangerous when close to an electrical power source. A mobile hydraulic crane is more vulnerable due to the natural maneuverability and versatility of the crane.

Extreme caution must be exercised by all personnel working with and around your crane when in the proximity of an energized power source or power lines.

All personnel must be adequately warned of safety procedures.

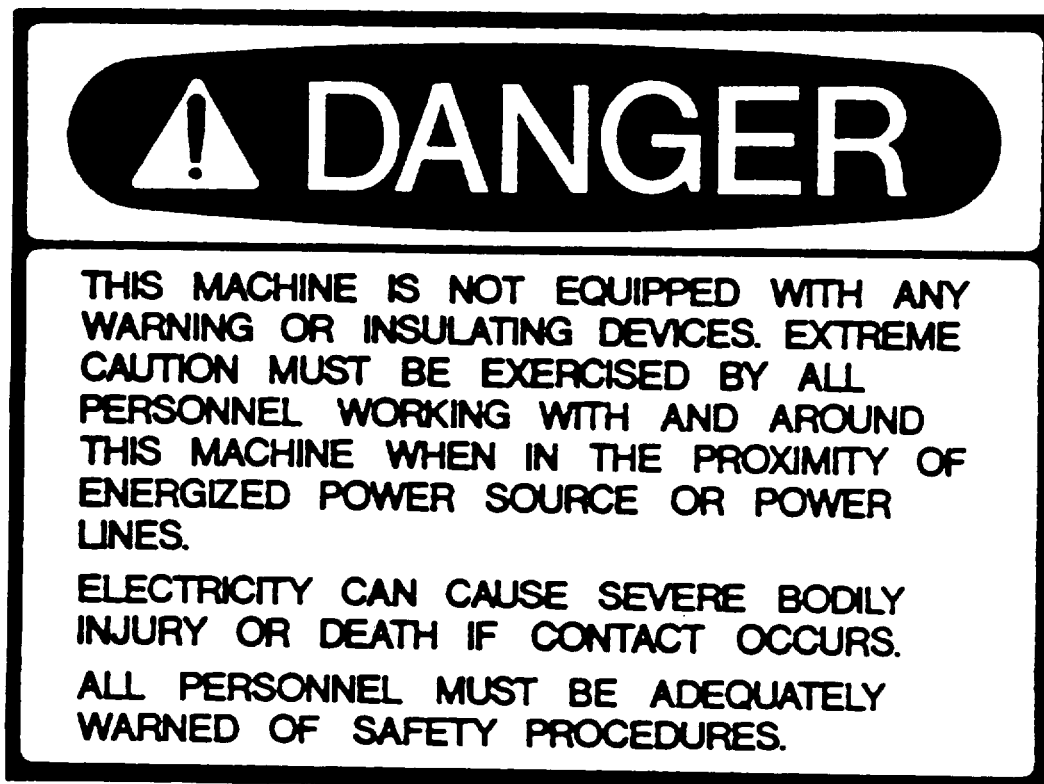

Assume all power sources are electrically energized ("hot" or "live") until you have absolutely reliable information to the contrary.

When operating in the vicinity of power lines, have the power company cut off the power and ground the lines. Obey the following rules, at all times whether the power is cut off or not.

Position the crane far enough away from power sources to ensure that no part of the crane or load can reach to within an unsafe zone. This includes the crane boom (fully extended to maximum height, radius, and length) and all attachments (jibs, boom extensions, rigging, tag lines, etc.).

Erect a suitable barricade to physically restrain the crane and all attachments (including the load) from entering into an unsafe distance from the power source.

Obtain positive and absolute assurance that power has been turned OFF.

Anytime there is the possibility of the boom or any part of the crane coming in contact with or close proximity of any overhead electrical lines, cables, or other obstructions such as bridges, gantries, pipework, scaffolding, or buildings, the crane operator must work under the direction of a single person so positioned to have a clear and unobstructed view of the work area. The observer must observe for adequate clearances, and stop craning operations anytime adequate clearances are not available.

When working near overhead electrical lines or cables, the crane frame must be positioned no closer (to the vertical plumb line of the nearest cable) than a distance equal to the maximum main boom and jib length plus 20 ft (6 m) as measured along the ground. If it should become necessary to work within this area, the electrical power company should be notified before work is begun.

Precautions must be taken to ensure that the crane is not working or parked over any underground services (gas mains, water mains, electrical lines) or where this is necessary, the services must be adequately protected.

IMPORTANT Always consider the wire rope, hoist cable, pendant cables, tag lines, etc. as conductors of electricity.

EXERCISE EXTREME CAUTION AND PRUDENT JUDGMENT WHENEVER ELECTROCUTION HAZARDS EXIST OPERATE SLOWLY AND CAUTIOUSLY.

Federal law prohibits use of cranes closer than 10 ft (3.048 m) to power sources to be safe, double that (i.e. 20 ft [6.096 m]).

Comply with all federal, state, and local laws and regulations.

It is not necessary to touch a power line or power source to become electrocuted. Electricity, depending on magnitude, can jump or become induced into a crane. "Low" voltages can also be dangerous.

Be alert.

Keep all parts of the crane (ropes, lines, hook block, and load) at least 20 ft (6.096 m) from the power line.

Slow down crane operations.

Whenever a load, wire rope, crane boom or any portion of a crane contacts or approaches too closely to an electrical power source, everyone in, on, and around the crane can be seriously injured or killed!

THE ONLY SAFETY WAY TO OPERATE A CRANE IS TO STAY AWAY FROM ELECTRICAL SOURCES!

Assume that every power line is "hot." Appoint a reliable and qualified signal person, equipped with a loud signal whistle or horn and voice communication equipment, to warn the operator when any part of the crane or load moves near a power source. This person should have no other duties while the crane is working.

Warn all personnel of danger. Allow no unnecessary personnel in the area. Permit no one to lean against or touch the crane. Permit no one including sling men or load handlers to hold load, lines, or rigging gear.

Even if the crane operator is not affected by an electrical contact, others in the area may become seriously injured or killed.

The use of boom guards, proximity devices, insulated hooks, links, or mechanical limit stops does not assure safety. Even if codes or regulations require the use of such devices, failure to follow rules listed here may result in serious injury or death. You should be aware of some of the limitations of the devices.

Boom Cage/Guards afford limited protection from the electrocution hazards. They are designed to cover only the boom-nose/point, and a portion of the boom. Performance of boom cages/guards is limited by their physical lengths, insulating characteristics, and the operating environment (e.g. dust, dirt, moisture, etc.).

Insulating links installed into the load-line afford limited protection for those handling the load. Links have limited lifting, insulating, and other properties that affect their performance. Moisture, dust, dirt, oils, etc. can cause a link to conduct electricity. Due to their capacity ratings, some links are not effective for large cranes and/or high voltages/currents.

The only protection afforded by a link is that which is obtained below the line electrically downstream, provided the link has been kept clean and free of contamination and is periodically (right before use) tested for its dielectric integrity.

Proximity sensing devices are available in different types. Some use boom nose (localized) sensors and others use full boom length sensors. No warning may be given for components, cables, loads, etc. located outside of the sensing area. Much reliance is placed upon you, the operator, in selecting and properly setting the sensitivity of these devices.

Never rely solely on a device to protect you and your fellow workers from danger! Some variables which you must be aware of with regard to proximity devices, are:

1. Proximity devices are supposed to detect the existence of electricity not it's quantity or magnitude.
2. Some proximity devices will detect only alternating current (AC) not direct current (DC).
3. Some devices detect radio frequency (RF) energy others do not.
4. Most proximity devices simply provide a signal (audible, visual, or both) for the operator the signal must not be ignored.
5. Sometimes the sensing portion of the proximity devices becomes confused by complex or differing arrays of power lines/sources.

Plan ahead and plainly mark a safe route before traveling under power lines. Erect rider poles on each side of the crossing to assure sufficient clearance is maintained.

Overhead power lines tend to blow with the wind. Allow for this when determining safe operating distances.

DO NOT store material under power lines or close to electrical power sources.

DO NOT depend on grounding!

Grounding of a crane affords little or no protection from electrical hazards. The effectiveness of grounding is limited by the size of the (wire) conductor used, the condition of the ground, the amount of the voltage and current present, etc. Power source contacts have been known to cause serious arcing due to grounding.

Tag lines should always be made of non-conductive materials.

Any tag line that is wet or dirty enough can conduct electricity.

Working in the vicinity of radio frequency transmission towers/sources may cause a crane to become electrically "charged." Survey the work site and develop specific safety precautions and operating procedures, prior to commencing operations.

If contact is made with a power source THINK DON'T PANIC.

1. Warn everyone to stay away from the crane.
2. Attempt to free the crane by operating the crane functions.
3. Stay in the crane until the power source has been deenergized.

Only as a Last Resort should an operator attempt to leave the crane upon contacting a power source.

If it is absolutely necessary to leave the operator station, JUMP COMPLETELY CLEAR OF THE CRANE DO NOT STEP OFF. Hop away with both feet together. DO NOT walk or run.

When operating cranes equipped with electromagnets you must take additional precautions.

- Permit no one to touch the magnet or load.
- Alert personnel by sounding a warning signal when moving a load.
- Do not allow the cover of the electromagnet power supply to be open during operation or at any time the electrical system is activated.
- Shut down the crane completely and open magnet control switch prior to connecting or disconnecting magnet leads.
- Use only a nonconductive device when positioning a load.
- Lower magnet to stowing area and shut off power BEFORE leaving the operator's cab.

Following any contact with an energized electrical source, thoroughly inspect the wire rope and all points of contact with the crane.

Advise your distributor of the incident and consult the factory for advice and crane inspection instructions prior to resuming operations.

2-7. PERSONNEL PLATFORMS**NOTE**

Platform as used herein is defined as any attachment made to a crane boom which is intended to elevate or position people and includes work baskets, cages, other devices for handling personnel.

WARNING

Handling of personnel from the boom is not authorized except with equipment furnished and installed by Grove Manufacturing Company. Written approval shall be obtained from Grove Manufacturing company prior to handling personnel.

2-8. COLD OR HOT WEATHER OPERATION CAUTION

Check operating procedures for cold weather starting. Clean the crane, especially the boom, of all ice and snow. Allow ample time for hydraulic oil to warm up. Before lifting ensure load is not frozen to the ground or other surface.

WARNING

Cold weather operation requires additional caution on the part of the operator. Don't touch metal surfaces that could freeze you to them. Never store flammable materials on the crane.

TOXIC AND FLAMMABLE

Starting fluid is toxic and highly flammable. Container is pressurized. NEVER heat container and NEVER discharge starting fluid in confined areas or near open flame. Severe injury to personnel may result. Use only the cold weather starting aid provided on your crane, use them. The use of aerosol spray or other types of starting fluids containing ether/volatilize can cause explosions or fire.

HEAT AND COLD STRESS

Operating the crane under extremely hot or cold ambient temperatures require special precautions to avoid operator fatigue, heat stress, frostbite or other health problems.

Refer to Technical Bulletins:

*TB MED 507 Occupational and Environmental Health. Prevent., Treatment, and Control of Heat Energy. (Jul-80)

*TB MED 81 Occupational and Environmental Health. Prevent., Treatment, and Control of Cold Energy. (Sept-76)

* FM 21-11 First Aid for Soldiers. Chapter 5, (10-88), Change 1. (8-89) and Change 2. (12-91)

* FM 21-10. Field Hygiene and Sanitation. Chapter 3, Section 1 and Section 2 (reprinted here). (11-88)

FM 21-10 Field Hygiene and Sanitation Chapter 3

SECTION 1 HEAT INJURIES

1. **DRINK PLENTY OF WATER.** Depending on the heat, you may need to drink from 1/2 quart (78°F to 81.9°F), to 2 quarts (90°F & above) of water per hour or 4 gallons or more per day in hot dry climates. Drink extra water before starting any mission or hard work. Cool water (50°F to 55°F) is absorbed faster than cold water. Drink small quantities frequently. Drink water even if you are not thirsty. Refill your canteens at every opportunity. Remember- If your urine is dark yellow, you are not drinking enough water. Thirst is not a good indicator of dehydration.
2. **USE WORK/REST CYCLES.** Work and rest as your leader directs. General guidelines are:
 - When the temperature is between 78°F to 81.9°F work 50 minutes and rest 10 minutes.
 - When the temperature is 90°F or above work 20 minutes and rest 40 minutes.
 - Work and rest in the shade, if possible.
3. **EAT ALL MEALS TO REPLACE SALT.** Take a salt solution only when directed by the medical personnel.
4. **MODIFY YOUR UNIFORM.** If directed/authorized by your commander: Unblouse pants from boots. Keep skin covered in the sun, remove shirt when working in the shade. Keep clothing loose at the neck, wrists, and lower legs. If the threat from biting insects is high, leave shirt sleeves down and pants bloused inside boots. **SECTION 2 COLD INJURIES**
 1. **WEAR UNIFORM PROPERLY.** Wear the clothing your commander directs. Wear clothing in loose layers (Top and Bottom). Avoid tight clothing including tight underwear. Keep clothing clean and dry. Remove or loosen excess clothing when working or in heated areas to prevent overheating that causes sweating. Wear headgear to prevent body heat loss. Avoid spilling fuel or other liquids on clothing (or skin).

2. **KEEP YOUR BODY WARM.** Keep moving, if possible. Exercise your big muscles (arms, shoulders and legs) frequently to keep warm. If you must remain in a small area, exercise your toes, feet, fingers and hands. Avoid the use of alcohol. Avoid standing directly on cold wet ground, when possible . Avoid tobacco products. The use of tobacco products decreases blood flow to your skin. Eat all meals to maintain energy. Drink plenty of water and/or drink warm nonalcoholic fluids, Dark yellow urine means you are not drinking enough fluids. You can dehydrate in cold climates too.
3. **PROTECT YOU FEET.** Bring at least five pairs of issue boot socks with you. Keep socks clean and dry. Change wet or damp socks as soon as possible, Beware of wet socks from sweating. Wash your feet daily if possible. Avoid tight socks and boots (lace boots as loosely as possible). Wear overshoes to keep boots dry.
4. **PROTECT OUR HANDS.** Wear gloves (with inserts) or mittens (with inserts). Warm hands under clothing if they become numb. Avoid skin contact with snow, fuel, and bare metal.
5. **PROTECT YOUR FACE AND EARS.** Cover your face and ears with a scarf or other material, if available. Wear your insulated cap with flaps down and around your chin. Warm your face and ears by covering them with your hands. Exercise facial muscles.
6. **PROTECT YOUR EYES.** Wear sunglasses to prevent snow blindness. Improvise sunglasses (slit goggles) if actual glasses are not available.
7. **PROTECT YOUR BUDDY.** Watch for signs of frostbite on his exposed skin pale /grey/waxy areas. Ask him if his feet, hands, ears, or face are numb and need warming. Do not let him sleep in or near the exhaust of a vehicle with engine running or in an enclosed area where an open fire is burning (carbon monoxide poisoning). Do not let him sleep directly on the ground. SEE FM-21-11, First Aid for Soldiers-for information on cold injury prevention and first aid.

NOISE

Hearing protection is required by the operator and all personnel within 36 feet of the vehicle while the engine is running or the crane is in operation. If you must raise your voice to be understood the continuous noise level is high enough to damage your hearing.

FIRE EXTINGUISHER

When using fire extinguisher, conduct all extinguishing operations from outside the cab, and ventilate the cab thoroughly prior to reentry. The fire extinguisher is located inside the cab below the main control panel on the left side.

2-9. DON'T FORGET THESE LOADING AND LIFTING LIMITS.

1. **DON'T EXCEED LOAD CHARTS.** Load charts represent the absolute maximum allowable loads , which are based on either tipping or structural limitations under specific conditions. Knowing the precise radius of operation, boom length, and angle should be a part of your routine planning and operation including necessary . Actual loads, including necessary allowances, should kept below these capacities.
2. **WATCH WORKING AREAS.** Working areas must be adhered to when determining allowable load from load charts (s).
3. **LEVEL CRANE USING LEVEL GAGE.** If the crane is not level, load capacities are reduced when lifting on the load side. Crane may appear to be visually level to you, but, in fact you may be being misled by optical illusions. Prior to any lifting operation use bubble gage as you level crane.
4. **WATCH LEVEL BUBBLE GAGE.** Watch gage as load is lifted. If bubble moves off center then the crane is beginning to tip. If you should encounter a tipping condition start lowering the load with the hoist line and retract or elevate the boom to bring the load in. Never lower or extend the boom, this will aggravate the condition.
5. **AVOID SUDDEN STOPS.** When using the hoist avoid sudden stops, increased loading will result and could cause tipping or a structural failure to occur.
6. **HYDRAULIC LINE BREAKAGE.** Even if a hydraulic line may be sheared or broken on the lift or crowd cylinders, the crane will still function sufficiently to get the load down.
7. **WATCH LIFTING CAPACITIES.** Maximum lifting capacity is available at the shortest radius, minimum boom length and the highest boom angle.

SECTION 3

PREPARATION FOR USE

3-1. SUMMARY.

The crane is shipped in an "operation-ready" condition requiring no maintenance or operator actions. However, it is recommended that a visual inspection of each system be made to ensure hydraulic, fuel, and coolant lines or fittings have not loosened or been damaged during transit from the manufacturer.

3-2. UNPACKING.

The following should be used as a check list while unpacking the crane.

- a. Remove the restraining strap on the cab door.
- b. The fire extinguisher must be placed in the mounting bracket located in the cab.

3-3. CHECKING UNPACKED EQUIPMENT.

- a. Inspect the equipment for damage incurred during shipment. If the equipment has been damaged, report the damage on Form DD Form 6, Packaging Improvement Report.
- b. Check the equipment against the packing slip to see if the shipment is complete. Report all discrepancies in accordance with the instructions of DA PAM 738-750.
- c. Check to see whether the equipment has been modified.

3-4. DEPROCESSING UNPACKED EQUIPMENT.

The crane should be clean and free of excess grease. However, if during inspection, any excess grease or lubricant is found on the frame or superstructure it should be cleaned immediately.

3-5. PRELIMINARY SERVICING AND ADJUSTMENT.

The crane is shipped completely serviced except for diesel fuel. Perform all B (Before) Preventive Maintenance Checks and Services (PMCS) prior to operating the crane for the first time. Refer to PMCS in Section 5. Report all faults to next higher level of maintenance.

A complete walk-around visual inspection of the crane should always be made before operation. Special attention should be given to structural damage, loose equipment, leaks, or other conditions that would require immediate correction for safe operation. The following checklist items are suggested specifically for the operator's benefit to make certain the crane is prepared for starting the days work.

- a. Fuel Supply/Fuel-Water Separator. Fill the fuel tank with approved diesel fuel and ensure that the cap is on tight. Then drain water from the fuel water separator. Refer to PMCS in Section 5.
- b. Engine Oil. Check oil level in the crankcase; fill the FULL mark on the dipstick. Do not overfill. Refer to PMCS in Section 5.
- c. Check coolant level in the radiator by inspecting the coolant recovery bottle level located in the engine compartment; fill to proper level. Do not overfill. Check cap for security. Refer to PMCS in Section 5.
- d. Fan Belt and Fan. Inspect fan belt for cracks or fraying. Inspect fan for cracks. Refer to PMCS in Section 5.
- e. Transmission. Check transmission oil level; fill if required. Refer to PMCS in Section 5.
- f. Air Cleaners. Check the air restriction indicator. Check filters and tubing for security.
- g. Muffler and Pipes. Inspect the exhaust system for corrosion, damage, and loose parts.
- h. Battery. Ensure the cables and clamps are tight and not corroded. Examine battery case for cracks or leaking electrolyte.
- i. Hydraulic Reservoir and Filter. Check hydraulic fluid quantity level gauge and check filter condition indicator. Check breather for cleanliness and security. If necessary, add hydraulic oil until oil appears half-way up in the sight gauge. Refer to PMCS in Section 5.
- j. Tires. Check for severe cuts, foreign objects imbedded in treads, and for correct inflation pressures. Refer to Tire Inflation Chart in Appendix E.
- k. Wire Rope. Inspect wire rope in accordance with PMCS in Section 5. Sheaves, guards, guides, drums, flanges, and any other surfaces that come in contact with the rope should be inspected for any condition that could cause possible damage to the rope.
- l. Hook Block. Visually inspect for nicks, gouges, cracks, and evidence of any other damage. Replace a hook containing cracks or showing evidence of excessive deformation of the hook opening (including twist). Be sure the safety latch is free and aligned.
- m. Horns, Signals, and Lights. Check all signal and running lights for proper operation. Replace burned out lamps with those of the same number, or equivalent. Ensure backup alarm and steering wheel horn are operable.
- n. Fire Extinguisher. Check the charge indicator dial to ensure the pointer is in the green zone.

- o. Foot and Parking Brake. Check brake fluid level in brake master cylinder. Access to the master cylinder is through a hole in crane deck directly in front of the operator's cab windshield. Check brake foot pedal and parking brake lever for proper operation. Refer to PMCS in Section 5.
- p. Windshield Washer Fluid. Check that the windshield washer fluid bottle is full. The bottle is located in the crane directly in front of the operator's cab front windshield. Refer to PMCS in Section 5.
- q. Daily Lubrication. Make certain that all components requiring daily lubrication have been serviced. Refer to PMCS ins Section 5.

SECTION 4

PRINCIPLES OF OPERATION

4-1. GENERAL.

The Model AP308T hydraulic crane is fully self-contained. All crane functions are either electrically or hydraulically controlled, and hydraulically operated. The main functions are raising and lowering the boom, extending or retracting the boom, raising and lowering loads with the hoist, swinging the boom, and extending and retracting the outriggers. Hydraulic cylinders activate the elevation, telescope, and outrigger systems. The hoist and swing systems are driven by hydraulic motors.

A diesel engine provides drive power for the main and steering hydraulic pumps and also drives an alternator which supplies electrical power for control, accessory, and lighting systems. The engine also provides power to the front drive axle through a transmission, to drive the crane.

Hydraulic flow and electrical power are transferred from the carrier to the superstructure by a hydraulic swivel with an electrical collector ring located at the center of rotation.

4-2. MAJOR COMPONENTS AND SYSTEMS.

- a. **Cab Assembly.** The fully enclosed cab is all steel with tinted safety glass windows throughout. The cab contains all controls and indicators for traveling and craning operations including outrigger control and level indicator. Access to the enclosed cab is via a hinged left side door which features a keyed lock and lockable sliding glass window. The crane is equipped with a door holding device which retains the door in the open position. The cab also contains the heater and defroster, electric windshield wiper, and a 10 BC-rated 2.75 lb (1.25 kg) fire extinguisher. The operator's seat features a hinged, padded armrest, fore/aft adjustment track, and a three-position height adjustment lever.
- b. **Carrier Frame Assembly.** The frame assembly is of hi-strength steel, all welded reinforced construction with integral outrigger boxes front and rear and full width decking. A rear pintle hook is provided.
- c. **Engine.** The diesel engine is housed in the engine compartment located to the rear of the crane. The engine is used to provide crane mobility, drive the hydraulic pump, supply electrical power to charge the battery, and provide power for crane control circuits, accessories, and lighting. All controls for the engine are located in the cab. The on-condition (OC) intervals for changing the engine lubricating oil and filter will be controlled (after the warranty period), by the Army Oil Analysis Program (AOAP).
- d. **Fuel Tank.** A single 35 gal. (132.4 L) total capacity and 30 gal. (113.5 L) gauge level capacity fuel tank is mounted on the right side of the crane. The tank is equipped with a lock-type filler cap, a fuel level sender unit, and a

shutoff valve. A Grove-supplied fuel stainer (mounted on the right side frame rail behind the fuel tank) is located in the fuel supply line.

- e. **Drive Train.** The drive train consists of an automatic transmission and drive line. The automatic transmission is a three-speed capable of providing automatic upshifts and downshifts through the three forward gear ratios. The transmission features an internal filter accessed by removing the fluid sump pan.

The on-condition (OC) intervals for changing the transmission fluid and internal filter will be controlled (after the warranty period), by the AOAP.

- f. **Axles.** The front drive axle is manufactured by Rockwell. It is a single reduction, solid-mounted drive axle with floating axle shafts and high traction differential.

The rear steer axle is a rigid-mounted, wide track axle and is manufactured by Grove.

- g. **Steering System.** The crane incorporates a hydraulically controlled steering system, utilizing a hydraulic steer cylinder mounted to the rear axle. A steering control valve directs flow from the hydraulic pump to the hydraulic steer cylinder to provide full power steering of the rear axle.

- h. **Brake System.** The service brakes are the hydraulic drum and floating shoetype and are installed on the front and rear wheels. The park brake consists of a brake and shoe assembly bolted to the transmission. The parking brake shoes are applied by pulling the cab-mounted lever. The lever pulls a cable attached to the brake cam. The cam is rocked as the cable is pulled thus applying the brake shoes.

- i. **Hydraulic System and Components.** The hydraulic system is designed to provide adequate pressure and volume for simultaneous operation of various crane functions.

- (1) **Reservoir.** The hydraulic reservoir is located on the right side of the crane chassis. The reservoir has a total capacity of approximately 35 gal. (132.4 L) and a gauge level capacity of approximately 30 gal. (113.5 L). The all-steel reservoir has an internally-mounted, full-flow filter and integral baffles that help cool the oil and prevent oil foaming.
- (2) **Hydraulic Oil Cooler.** The hydraulic oil cooler is mounted to the front of the crane under a bolt-on cover. The oil cooler fan draws cool air through the cooling fins on the cooler. It cools the oil utilized in the swing and telescope circuits.
- (3) **Pumps.** The crane utilizes a two-section pump mounted on and driven by the engine to supply the hydraulic system and a separate pump also driven by the engine to supply the steering system.

- (4) **Directional Control Valves.** The directional control valves are four-way, three-position valves with either an open or closed spool. The valves are grouped into valve banks permitting simultaneous independent control of crane functions. Each bank contains an integral main bypass for system relief and an individual circuit bypass relief valve.
- j. **Turntable Assembly and Swing Mechanism.** An anti-friction roller bearing supports the superstructure on the carrier and allows 360 degrees of continuous rotation (swing) in either direction. Swing is accomplished by a hydraulically driven motor driving a gear reducer which in turn drives a pinion that drives the roller bearing. A multi-disc-type brake that is an integral part of the gear reducer, is provided to stop swing, and hold the superstructure in the desired position.
- (1) **Swing Motor.** The hydraulic swing motor is a low-speed, high torque type. The motor provides indirect drive power for turntable swing through the gear reducer.
- (2) **Swing Planetary Gear Reducer.** The planetary gear reducer is a sun and planetary gear-type, driven by the swing motor. The gear reducer has a ratio of 27.98: 1.
- k. **Boom Assembly.** The boom is a 14 to 24 ft (4.2 to 7.3 m) two-section, full power boom and is trapezoidal in design. Boom elevation is from -0 to + 70 degrees.
1. **Hoist.** The hoist provides power and speed for all load raising and lowering operations. A van-type, hydraulic motor drives the hoist drum by means of a planetary gear reduction system.
- A metallic disc hoist brake is an integral part of the hoist assembly in that it is a spring-actuated brake which requires hydraulic pressure to release. In the event of a hydraulic system failure or if the load-drop speed is too fast, the hydraulic pressure in the hoist down line will decrease. This decrease in hydraulic pressure would cause the hoist brake to actuate which would then slow down or stop the hoist.
- m. **Outrigger System.** The outriggers are integral with the carrier frame and are controlled and operated from the cab. The outriggers are the oblique telescoping-type and consist of a removable beam and a cylinder assembly. A level indicator is located in the cab near the F-N-R-transmission lever, to aid in leveling the crane.
- n. **Swivels.** Electrical and hydraulic swivels are used to route electrical and hydraulic circuits from the boom to the carrier frame. These swivels are mounted as a single assembly, and are installed at the center of rotation.

- o. **Electrical System.** The electrical system is a 12-vdc operation with 12-vdc starting, consisting of an alternator and one maintenance-free, 12-volt lead-acid battery. The system is single-wire, ground return-type, utilizing the crane's structure as ground.
- p. **Heater/Defroster.** The cab heater is located under the operator's seat. Hot water from the engine coolant system flows through the coils of the heater.

Heated air is circulated in the cab by an electric motor-driven fan, controlled by heat level and fan speed control knobs on the left side of the seat.

- q. **Antitwo-block System.** The antitwo-block system provides a warning to the operator of an impending two-block condition. The system consists of an antitwo-block switch, a relay, a buzzer, a warning indicator light, and the associated wiring. The switch is held in the closed position by a weight suspended on a chain from the switch. The closed switch maintains the relay energized, which silences the buzzer and prevents illumination of the indicator light. As the hook block comes closer to the boom tip, it contacts the weight and the switch springs open. This action deenergizes the relay, which sounds the warning buzzer, and illuminates the WARNING indicator light on the PAT panel mounted on the main control panel.

SECTION 5

OPERATING INSTRUCTIONS

5-1. CONTROLS AND INDICATORS.

NOTE

The following paragraphs describe the controls and indicators located in the cab. The numbers in parentheses () represent the index number from Figure 5-1.

5-1.1 Engine Controls and Indicators.

- a. **Converter Oil Temperature Gauge.** The converter oil temperature (OIL TEMP) gauge (34) located on the top left side of the main control panel.

The gauge indicates the temperature of the transmission oil on a dual scale calibrated from 140° to 320°F (60° to 160°C). The gauge receives a signal from a temperature sending unit in the oil line at the converter. The gauge has a green scaled area indicating acceptable operation temperatures and a red scaled area indicating excessive temperature.

- b. **Engine Oil Pressure Gauge.** The engine oil pressure (OIL PRESS) gauge (36) is located on the top left side of the main control panel. The gauge indicates the engine oil pressure on a dual scale calibrated from 0 to 100 psi (0 to 690 kPa). Normal indication at idle is 10 psi (70 kPa), at high idle is 35 psi (241 kPa), and at maximum governed speed is 85 psi (586 kPa). The gauge receives its signal from an oil pressure sending unit.
- c. **Engine Coolant Temperature Gauge.** The engine coolant temperature (WATER TEMP) gauge (35) is located on the top left side of the main control panel. The gauge receives a signal from a temperature sending unit in the engine cooling system. The gauge has a green scaled area indicating acceptable operating temperatures [up to 210°F (99°C)] and a red scaled area indicating excessive temperature.
- d. **Fuel Quantity Gauge.** The FUEL quantity gauge (32) is located on the bottom left side of the main control panel. The gauge indicates the quantity of fuel in the tank and has a scale calibrated from 0 to 4/4. The fuel quantity gauge receives a signal from a sending unit in the fuel tank.
- e. **Ignition Switch.** The IGNITION switch (28) is located on the left side of the main control panel. It is a key-operated switch with four positions; ACC, OFF, ON, and START. With the switch in the OFF position, all electrical power is off. Positioning the switch to ACC energizes all electrical components. Positioning the switch to ON is the same as ACC. Placing the switch to START energizes the starter relay which in turn energizes the cranking motor solenoid and cranks the engine for starting. Releasing the switch will spring return it to ON. To shut down the engine, place the switch to OFF.

- f. **Foot Throttle Pedal.** The foot throttle pedal (7) is located on the right side cab floor. The pedal operates the engine speed through a control cable. Depressing the pedal increases engine speed. Releasing the pedal returns the engine to the idle speed.
- g. **Voltmeter.** The voltmeter (BATTERY) (33) is located on the bottom left side of the main control panel. With the IGNITION switch (28) in the ON position and before starting the engine, the voltmeter shows the condition of the batteries. With the engine running, the voltmeter indicates output voltage of the alternator. The voltmeter indicates voltage from 10 to 16 volts. Normal indication is from 12 to 14 volts.
- h. **Hourmeter.** The hourmeter (3) is located on the right side of the main control panel. The engine HOURS operates whenever the diesel engine is running.
- i. **Low Oil Pressure/High Engine Temperature Indicator.** The LO OIL PRESS/HI ENG TEMP indicator (42) is located on the right side of the main control panel. The system provides a warning for low pressure and/or high water (coolant) temperature. The activation of either the oil pressure switch or water temperature switch will illuminate the red indicator light and sound the buzzer. The low oil pressure switch activates if oil pressure is between 2 to 5 psi (13.7 kPa/0.137 bar to 34.4 kPa/0.34 bar) and the water temperature switch activates if the coolant temperature exceeds 205° F (96° C).
- j. **Cold Start Switch.** The COLD START switch (6) is located on the lower right side of the main control panel and is placarded with a caution. The switch is the pushbutton-type and is used to inject shots of starting aid into a cold engine during starting. The ignition switch must be in the START position for quick start operation.

5-1.2 **Accessory Controls and Indicators.**

- a. **Horn Button Switch.** The horn button switch (23) is located in the center of the steering wheel. Depressing the horn sounds a lo-tone horn mounted on the front of the crane.
- b. **Turn Signal/Four-Way Flasher.** The turn signal and four-way flasher switch (25) is located on the steering column forward of the steering wheel. Positioning the turn signal lever (longer of the two levers on the switch) to the left causes the left front and left rear turn signals to flash and positioning it to the right causes the right front and right rear turn signals to flash. Pulling straight out on the short lever located behind the turn signal lever causes all four turn signals to flash. The indicator light on the turn signal switch shows that the turn signals are in operation by flashing simultaneously with the front and rear signals.

Push the short lever in to turn off the four-way flashers.

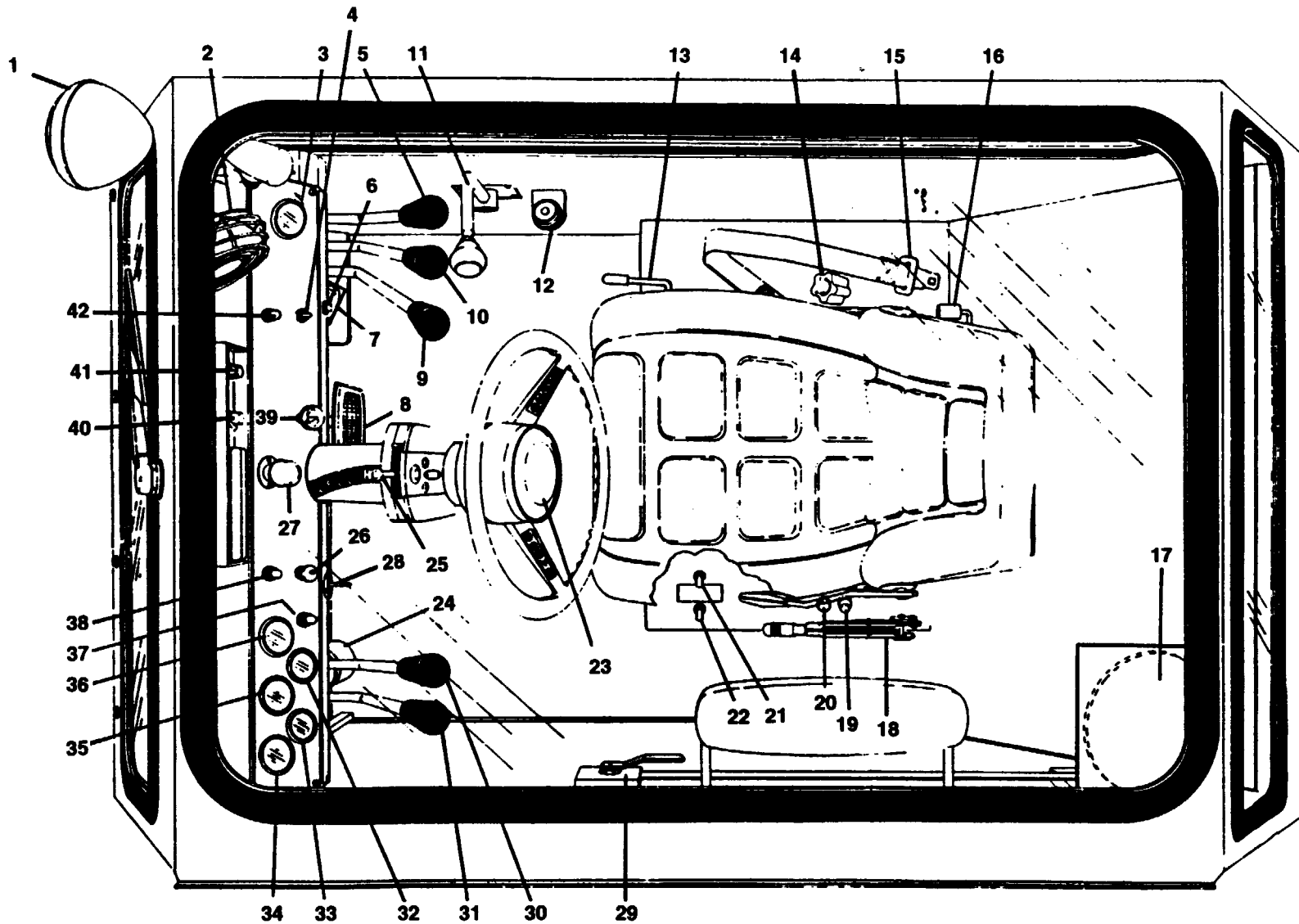

See Sheet 2 for Detail View
of Main Control Panel

Figure 5-1. Cab Controls and Indicators (Sheet 1 of 2)

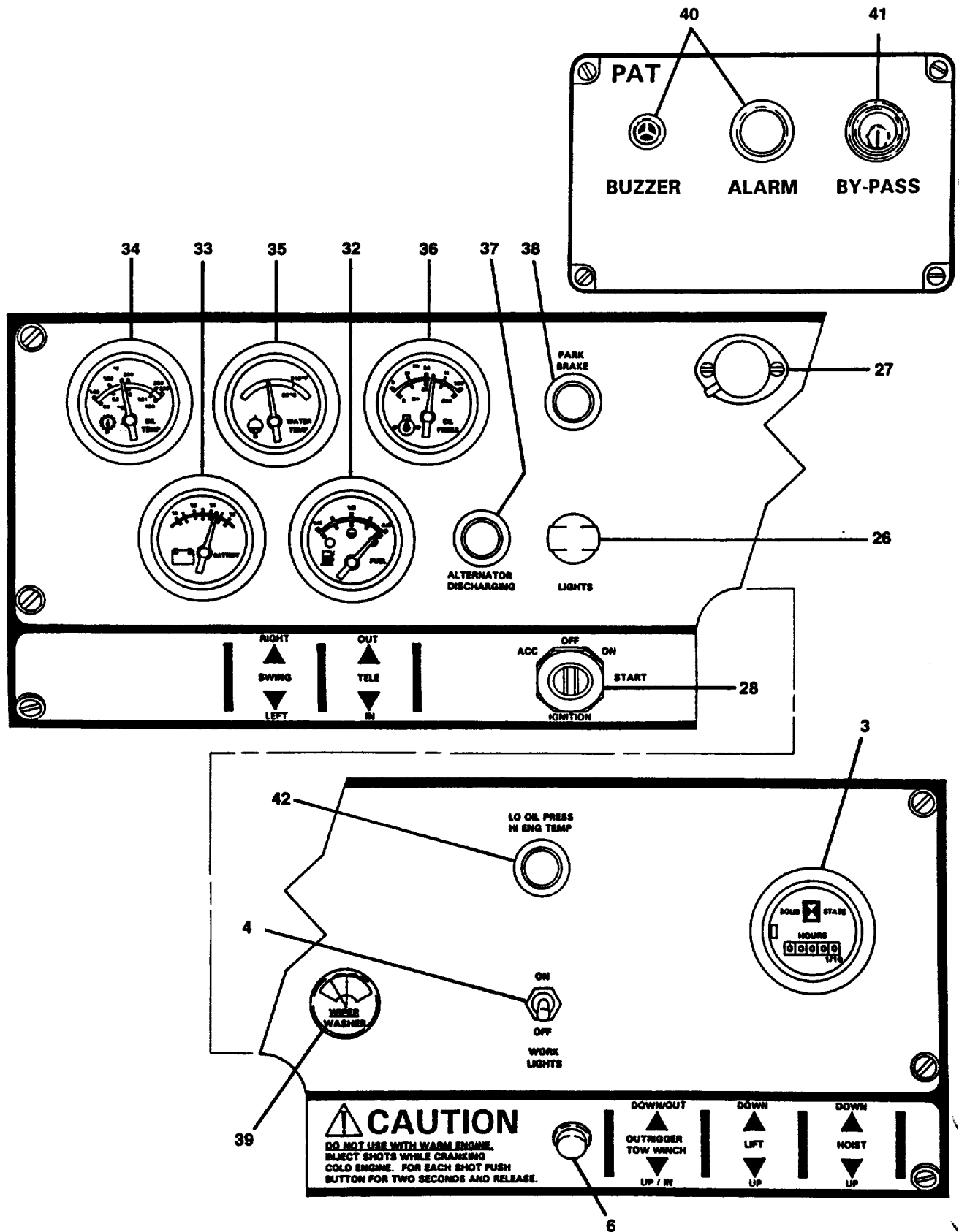

Figure 5-1. Cab Controls and Indicators (Sheet 2 of 2)

Legend for Figure 5-1.

1.	Spotlight	23.	Horn Button Switch
2.	Cab Circulating Fan	24.	Fire Extinguisher
3.	Hourmeter (HOURS)	25.	Turn Signal/Four Way Flasher
4.	Boom (WORK LIGHTS) Switch	26.	LIGHTS Switch
5.	HOIST Control Lever	27.	Panel Lamp
6.	COLD START Switch	28.	IGNITION Switch
7.	Foot Throttle Pedal	29.	Door Latch with Lock
8.	Foot Brake Pedal	30.	TELEscope Control Lever
9.	OUTRIGGER Control Lever	31.	SWING Control Lever
10.	LIFT Control Lever	32.	FUEL Quantity Gauge
11.	1-2-D-N-R Control Lever	33.	Voltmeter (BATTERY)
12.	Level Indicator	34.	Converter OIL TEMPerature Gauge
13.	Seat Slide Adjustment Lever	35.	Engine WATER TEMPerature Gauge
14.	Seat Back Lumbar Support Knob	36.	Engine OIL PRESSure Gauge
15.	Seat Belt	37.	ALTERNATOR DISCHARGING Indicator
16.	Seat Height Adjustment Lever	38.	PARK BRAKE Indicator
17.	Dome Light	39.	Windshield WIPER/WASHER Switch
18.	Park Brake Lever	40.	Two-block ALARM Indicator
19.	Heater/Defroster FAN Switch	41.	Two-block BY-PASS Switch
20.	Heater/Defroster Air TEMPerature Control	42.	LOW OIL PRESSure/High ENGINE TEMPerature Indicator
21.	OUTRIGGER SELECTOR Switch (R)		
22.	OUTRIGGER SELECTOR Switch (L)		

- c. **Lights Switch.** The LIGHTS switch (26) is located on the main control panel to the left of the steering column. The switch is a push-pull-type switch with a rheostat control. The switch must be pulled to the second detent to illuminate the gauge lights on the console, the clearance lights, tail lights, and headlights. Rotating the switch knob controls the brightness of the panel gauge lights.
- d. **Panel Lamp.** The panel lamp (27) is located on the top center of the main control panel. The switch (located at the base of the lamp), is a two-position, on-off switch. Positioning the switch to ON energizes the lamp.
- e. **Dome Light.** The dome light (17) is located on the left rear side of the cab. The light is illuminated by a switch on the light.
- f. **Windshield Wiper/Washer Switch.** The windshield WIPER/WASHER switch (39) is located to the right of the steering column on the main control panel. The switch has three positions corresponding to off, low speed, and high speed. Rotating the switch knob to the first detent energizes the wiper motor at low speed and rotating it to the second detent energizes the motor at high speed. Rotating the switch knob to the counterclockwise position stops the motor and causes the automatic park function of the wiper motor to return the wiper blade to the parked position. Pushing the switch knob energizes the motor on the windshield washer pump assembly.

- g. **Heater/Defroster Air Temperature Control.** The heater/defroster air TEMP control (20) is located on the left side of the cab beside the seat.

It is a push-pull cable control that positions the temperature control on the heater unit. Pull the control knob for warm air and push it in for cool air.

- h. **Heater/Defroster Fan Switch.** The heater/defroster FAN switch (19) is located on the left side of the cab beside the seat to the rear of the heater/defroster air TEMP control. The switch controls the flow of air and has three positions; OFF, HI, and LO.
- i. **Cab Circulating Fan.** The cab circulating fan (2) is located on the dash on the right side of the cab. It is mounted to a ball joint so it can be directed to different parts of the cab.
- j. **Fire Extinguisher.** The fire extinguisher (24) is retained in a bracket mounted below the main control panel on the left side.
- k. **Spotlight.** The spotlight (1) is located on the right side of the cab. It can be rotated 360 degrees and is illuminated by an on-off switch located on the spotlight handle.
- l. **Alternator Discharging Indicator.** The ALTERNATOR DISCHARGING indicator (37) is a red flashing light located on the main control panel to the left of the steering wheel. The light flashes whenever there is a failure in the battery charging system.
- m. **Boom Light Switch.** The boom light (WORK LIGHT) switch (4) is located on the lower right side of the main control panel. The switch is an ON/OFF toggle switch that turns on the two work lights mounted on the boom base section.
- n. **Level Indicator.** A level indicator is (12) installed on the right side of the cab in front of the shift lever. The indicator provides the operator with a visual indication for determining the levelness of the machine.
- o. **Operator's Seat Controls.** There are three adjustments for the operator's seat. The first is a lever (13) that enables the seat to slide up and back. The second is a knob (14) which controls the seat back lumbar support. The third is a lever (16) to adjust the seat height. The seat features a seat belt (15) and a documentation storage bag attached to the seat back.
- p. **Cab Door Latch and Lock.** A keyed cab door latch and lock (29) can be used to secure the crane cab. If locking the cab door, be sure to slide the cab door window shut until the window locking mechanism latches.

5-1.3 **Crane Controls and Indicators.**

- a. **Foot Brake Pedal.** The foot brake pedal (8) is located to the right of the steering column next to the accelerator pedal. Depressing the pedal actuates a master cylinder that applies the hydraulic service brakes.

- b. **Park Brake Lever.** The park brake lever (18) is located on the left side of the cab beside the seat. The lever operates the parking brake by a control cable. Pushing down (forward) on the lever moves the control cable to apply the band brake on the transmission tailshaft. Pulling up (back) on the lever moves the cable to release the band brake on the transmission tailshaft. A pushbutton microswitch on the lever controls the PARK BRAKE light (38) on the main control panel.
- c. **1-2-D-N-R Transmission Control Lever.** The transmission control lever (11) is located on the right side of the cab in front of the level indicator. The lever has five positions; 1 (first or low gear), 2 (second gear), D (drive forward), N (neutral), and R (reverse).
- d. **Swing Control Lever.** The swing control lever (31) is the leftmost lever on the left side of the main control panel. The lever when positioned to RIGHT or LEFT, actuates a control valve through linkage rods to provide swing in the desired direction.
- e. **Telescope Control Lever.** The TELE control lever (30) is the first control lever to the left of the steering column. The lever when positioned to OUT or IN actuates a control valve through linkage rods to extend or retract the boom.
- f. **Outrigger Control Lever.** The OUTRIGGER lever (9) is the first lever to the right of the steering column. The lever when positioned to DOWN/OUT or UP/in actuates a control valve through linkage rods to position the outrigger(s) as selected by the outrigger selection switch.
- g. **Outrigger Selector Switch.** The OUTRIGGER SELECTOR (Right Side Outriggers) switch (21) is located on the left side of the cab beside the seat. Positioning the lever to RIGHT FRONT or RIGHT REAR while operating the OUTRIGGER control lever chooses which right side outrigger is to be actuated.
- h. **Outrigger Selector Switch.** The OUTRIGGER SELECTOR (Left Side Outriggers) switch (22) is located on the left side of the cab beside the seat. Positioning the lever to LEFT FRONT or LEFT REAR while operating the OUTRIGGER control lever chooses which left side outrigger is to be actuated.
- i. **Lift Control Lever.** The LIFT control lever (10) is located to the right of the steering column to the left of the hoist control lever. Positioning the lever to UP or DOWN actuates a control valve through linkage rods to raise and lower the boom.
- j. **Hoist Control Lever.** The HOIST control lever (5) is the right most control lever on the main control panel. Positioning the lever to DOWN or UP actuates a control valve through linkage rods to drive the hoist and raise and lower the hoist cable.

- k. **Two-block Indicator.** The two-block (ALARM) indicator (40) is in a panel located above the main control panel. The indicator is a red ALARM light that illuminates when the antitwo-block switch is actuated, indicating a two block condition. A BUZZER also sounds when the light illuminates. Refer to paragraph 4-2q for a more detailed description of the antitwo-block system operation.
- l. **Two-block Lockout Override.** The two-block lockout override (BY-PASS) switch (41) is a two-position keyed switch placarded NORMAL and OVERRIDE and is located to the right of the ALARM indicator light. With the switch in NORMAL, two-block lockout will occur. With the switch in OVERRIDE, the lockout solenoid valve is energized to open the valve and allow two-block lockout override.
- m. **Backup Alarm.** (Not shown) The backup alarm is an audible alarm used to warn personnel when the crane is backing up. The backup alarm system is electrical and consists of the backup alarm and associated wiring. The alarm is connected into the backup light electrical wiring, and is activated when the backup light is used. The backup alarm is installed on the right rear side of the frame.
- n. **Park Brake Indicator.** The PARK BRAKE indicator (38) is located on the left side of the main control panel. A pushbutton micro-switch located on the park brake lever lights the indicator if the park brake is engaged.

5-2. PREVENTIVE MAINTENANCE CHECKS AND SERVICES (PMCS).

5-2.1 General.

- a. Before you operate. Always keep in mind the CAUTIONS and WARNINGS. Perform your before (B) PMCS.
- b. While you operate. Always keep in mind the CAUTIONS and WARNINGS. Perform your during (D) PMCS.
- c. After you operate. Be sure to perform your after (A) PMCS.
- d. If your equipment fails to operate. Troubleshoot with the proper equipment. Report any deficiencies using the proper forms. See TM 38-750.

5-2.2 Procedure.

PMCS procedures in the table are intended to insure that the crane is ready to be operated safely with minimum crane wear and tear.

The PMCS table lists the checks and services that need to be performed at various intervals. The intervals were determined by crane design and expected use.

- a. "Before" or (B) PMCS shall be performed by the operator prior to starting the engine and attempting to operate the crane.

- b. "During" or (D) PMCS shall be performed while operating the crane both while sitting in the cab manipulating the controls and when outside the cab doing other tasks associated with operations.
- c. "After" or (A) PMCS shall be performed after crane operation and when it is being shut down for a period of time.
- d. "Weekly" or (W) PMCS need not be performed every day or every time the crane is operated, but must be done relatively frequently, and not delayed or forgotten. A weekly routine must be established to check and service these items.
- e. "Monthly" or (M) PMCS provides checks and services that need not be done weekly but cannot be ignored more than a month. A monthly service routine must be established.
- f. There are checks and services that must be done on the basis of the number of hours of engine operation, or based on special environmental conditions. These more frequent checks are marked with an asterisk. An appropriate footnote explains the special service interval.

5-2.3 Additional Special Checks and Services.

Perform weekly (W) as well as before (B) operations PMCS if:

- a. You are the assigned operator and have not operated the crane since the last weekly.
- b. You are operating the crane for the first time.

5-2.4 Leakage Definitions.

Leakage definitions for operator/crew PMCS shall be classified as follows:

- Class I Seepage of fluid (as indicated by wetness or discoloration) not great enough to form drops.
- Class II Leakage of fluid great enough to form drops but not enough to cause drops to drip from item being checked/inspected.
- Class III Leakage of fluid great enough to form drops that fall from the item being checked/inspected.

CAUTION

Equipment operation is allowable with minor leaks (Class I or II). Of course, you must consider the fluid capacity in the item/system being checked/inspected. When in doubt, notify your supervisor.

When operating with Class I or II leaks, continue to check fluid levels as required in your PMCS.

Class III leaks should be reported to your supervisor or organizational maintenance.

5-2.5 Equipment Not Ready If:

This column provides a clear description of the conditions in which the crane shall not ever, unequivocally, be operated, due to personnel safety and/or prospect of equipment damage.

Deficiencies in the crane and its performance shall be reported to your supervisor, and/or to your organizational maintenance group on Form 2408-X as well as noted in the Equipment Daily Log, Form 2408-1.

PMCS can be performed by the operator without removing any assemblies.

5-2.6 General Safety Precautions.

It is impossible to compile a list of safety precautions covering all situations. However, there are basic safety precautions that MUST be followed during your daily routine. Safety is YOUR PRIME RESPONSIBILITY, since any piece of equipment is only as safe AS THE PERSON AT THE CONTROLS.

With this thought in mind, Section 2 of the operator's manual will assist you, the operator, in promoting safe working atmosphere for yourself and those around you. It is not meant to cover every conceivable circumstance which could arise. It is intended to present basic safety precautions that should be followed in daily operation.

Because you, the operator, are the only part of the crane that can think and reason, your responsibility is not lessened by the addition of operational aids or warning devices. Indeed, you must guard against acquiring a false sense of security when using them. They are there to assist, NOT direct the operation. Operational aids or warning devices can be mechanical, electrical, electronic, or a combination thereof. They are subject to failure.

You, the operator, are the only one who can be relied upon to assure the safety of yourself and those around you. Be a PROFESSIONAL and follow the RULES of safety.

REMEMBER, failure to follow just one safety precaution can cause an accident to people and equipment.

You are responsible for the safety of yourself and of those around you.

Ensure you and those working with you are aware of any special dangers where you are operating the crane. Be especially careful of dangerous ground and objects, including buildings, near the crane.

Be aware at all times that you are responsible for the safety of yourself, your coworkers, the crane, and everything around it. Make certain the crane is properly maintained, and then pay attention to winds, boom deflections, rope sway, and any unusual things, which you, as a crane operator, may notice which would not be important to others.

Know and abide by the basic safety rules.

Read and understand the Operator's Manual before entering the cab.

Follow directions on all placards. Know what they mean and follow their instructions.

Operators must be thoroughly familiar with safe crane operating practices and have a complete understanding of all operation and maintenance instructions provided. Operators should be physically fit and thoroughly trained, with related experience, not be easily excitable, not be subject to epileptic seizures, and not be using any drug that could impair physical, visual, or mental reactions or capabilities.

Wear the proper clothing for the job. Wear personnel protective equipment as required by local or job regulations.

Inspect the crane every day (before the start of each shift). Ensure that routine maintenance and lubrication are being dutifully performed. Do not operate a damaged or poorly maintained crane. You risk lives when operating faulty machinery, including your own.

5-2.7 Diesel Fuel Recommendations/Specifications

WARNING

Do not mix gasoline or alcohol with diesel fuel. This mixture can cause an explosion.

NOTE

Any adjustment to compensate for reduced performance with a fuel system using alternate fuel is not warrantable. Also, wear on any midrange fuel pump component attributed to the lack of lubrication in the fuel is not a warrantable repair.

Use ASTM No. 2-D fuel with a minimum Cetane number of 40. No. 2 diesel fuel gives the best economy and performance under most operating conditions. Fuels with Cetane numbers higher than 40 may be needed in high altitudes or extremely low ambient temperatures to prevent misfires and excessive smoke. At operating temperatures below 32°F (0°C), use a blend of No. 1-D and No. 2-D fuels, also known as "winterized" No. 2-D.

Use low sulfur content fuel having a cloud point that is at least 10 degrees below the lowest expected fuel temperature. Cloud point is the temperature at which crystals begin to form in diesel fuel. The viscosity of the fuel must be kept above 1.3 centistokes to provide adequate fuel system lubrication at 104°F (40°C).

Acceptable Alternate Fuel Types:

Acceptable Alternate Fuel Types (if 5% new lube oil is blended with these fuels to increase the lubricity):

Unacceptable Fuel Types:

*No. 1-D Diesel and No. 2 Fuel Oil
No. 1-K Kerosene, No. 2-K Kerosene,
Jet-A, Jet A-1, JP-5, and JP-8
Jet-B, JP-4, and Cite*

Table 5-1. Operator Preventive Maintenance Checks and Services

ITEM NO.	INTERVAL	ITEM TO BE CHECKED OR SERVICED	PROCEDURE	NOT FULLY MISSION CAPABLE IF
	B			
1	BEFORE	Lights/Horn	<p>a. Check for cracked or broken lenses.</p> <p>b. With IGNITION switch ON, check all lights for proper working order. Depress horn button, horn should sound.</p>	<p>a. Any lens cracked or broken.</p> <p>b. Any light or horn inoperable.</p>
2	BEFORE	<p>Fire Extinguisher</p> <p>Boom Angle Indicator</p> <p>Outrigger Float Pads</p>	<p>SAFETY & LOCKING DEVICES</p> <p>Check charge indicator.</p> <p>Check for proper operation. Raise and lower boom. Indicator must move from 0 to 70° without sticking or binding.</p> <p>Ensure outrigger float pads are installed properly. Check for cracked or broken structures and welds.</p>	<p>Indicator in red zone.</p> <p>Boom angle indicator is inoperative, missing, or binds/sticks.</p> <p>Item not installed correctly. Cracks or broken welds detected.</p>
3	BEFORE	Tires	<p>WARNING</p> <p>Always use tire inflation cage and clip-on inflator as tire rim parts can fly apart with lethal force.</p> <p>Inspect tires for excessive wear, cuts, low air pressure, or flat tires. The tire inflation chart is located in Appendix E, Sheet 9.</p>	<p>Low tire air pressure, flat/cut tire, or excessive wear.</p>

Table 5-1. Operator Preventive Maintenance Checks and Services Continued

ITEM NO.	INTERVAL	ITEM TO BE CHECKED OR SERVICED	PROCEDURE	NOT FULLY MISSION CAPABLE IF
	B			
4	BEFORE	Antifreeze & Coolant	<p>WARNING The cooling system is pressurized. Personal injury may result when removing the radiator cap after operating temperature is reached. Do not remove radiator cap when radiator is hot to touch.</p> <p>a. Check for proper coolant level (HOT or COLD) on coolant recovery tank given the engine temperature.</p>  <p>b. Inspect radiator hoses and clamps for damage, security, and evidence of leaks.</p>	<p>a. Coolant level low; Class III leaks exist.</p> <p>b. Hoses/clamps damaged, loose, or missing; Class III leaks exist.</p>

Table 5-1. Operator Preventive Maintenance Checks and Services Continued

ITEM NO.	INTERVAL	ITEM TO BE CHECKED OR SERVICED	PROCEDURE	NOT FULLY MISSION CAPABLE IF
	B			
5	BEFORE	Transmission	<p>Check for correct fluid level on transmission fluid dipstick with engine running at normal operating temperature. The "Hot" reading should have the fluid level in the cross-hatched area. The "Cold" reading should have the fluid level between the two holes punched in the dipstick.</p> 	Transmission fluid level low; Class III leaks exist.
6	BEFORE	Engine	<p>Check engine Crankcase crankcase oil level. Maintain oil level within cross-hatched area on dipstick (between arrows).</p> 	Engine oil level low; Class III leaks exist.

Table 5-1. Operator Preventive Maintenance Checks and Services Continued

ITEM NO.	INTERVAL	ITEM TO BE CHECKED OR SERVICED	PROCEDURE	NOT FULLY MISSION CAPABLE IF
	B			
7	BEFORE	Hydraulic Reservoir & Filter	<p>CAUTION Ensure all hydraulic cylinders are fully retracted when checking hydraulic fluid level.</p> <p>a. Check sight gage (on front of hydraulic tank) for proper oil level. Ensure that oil is visible half-way up sight gage. Reservoir capacity is 35 gallons; gage level is 30 gallons.</p> <p>b. Check condition of hydraulic oil filter indicator located on the filter head. Red flag indicates fouled filter element.</p> <p>c. Inspect hydraulic tank breather for cleanliness and security.</p>	<p>Hydraulic oil level low; Class III leaks exist.</p> <p>b. Red flag appears.</p> <p>c. Hydraulic tank breather is fouled or loose.</p>
8	BEFORE	Air Cleaner	<p>a. Check condition of air filter indicator located in air intake piping. Red flag indicates fouled filter element.</p> <p>b. Inspect filter housing, air intake piping, and all clamps for damage and security.</p>	<p>a. Red flag appears.</p> <p>b. Filter housing, air intake piping, and/or clamps damaged, loose, or missing.</p>

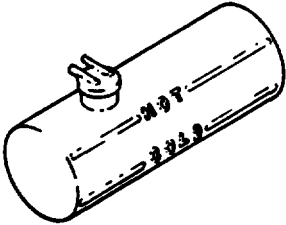
Table 5-1. Operator Preventive Maintenance Checks and Services Continued

ITEM NO.	INTERVAL	ITEM TO BE CHECKED OR SERVICED	PROCEDURE	NOT FULLY MISSION CAPABLE IF
	B			
9	BEFORE	Hydraulic Oil Cooler	Inspect hydraulic oil cooler for evidence of leaks and dirt restricting air flow through cooler.	Hydraulic oil cooler contaminated or leaks.
10	BEFORE	Wire Rope	<p>a. Inspect wire rope, rope sockets, and fittings for damage, wear, corrosion, heat damage, and lack of lubrication. Ensure that all components are properly installed and secure.</p> <p>b. Inspect sheave guards, guides, drums, flanges, and other surfaces that come in contact with wire rope for sharp edges, burrs, and corrosion that could damage wire rope.</p>	<p>a. Refer to paragraph 2-4 for wire rope safety criteria.</p> <p>b. Any component damaged and/or corroded.</p>
11	BEFORE	Boom Sheaves & Hook Block	<p>a. Inspect boom sheaves and hook block to ensure all components are properly installed and secure.</p> <p>b. Inspect hook block for cracks, damage, and deformed hook.</p> <p>c. Inspect boom and boom nose sheaves for excessive dirt, grease, and foreign matter.</p>	<p>a. Any component loose, damaged, or not installed properly.</p> <p>b. Hook block cracked, damaged, or</p> <p>c. Excessive dirt, grease, or foreign matter.</p>

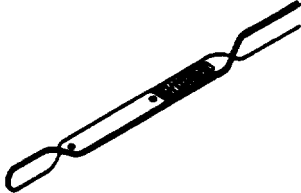
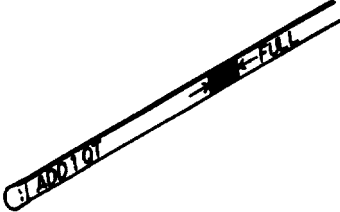
Table 5-1. Operator Preventive Maintenance Checks and Services Continued

ITEM NO.	INTERVAL	ITEM TO BE CHECKED OR SERVICED	PROCEDURE	NOT FULLY MISSION CAPABLE IF
	B			
12	BEFORE	Hoist Drum and Motor	<p>a. Check for proper operation while operating machine by attaching a test weight to the hook block. Then raise and lower load several times. Ensure hoist motor and brake operate smoothly.</p> <p>b. Inspect hoist hydraulic lines for damage, security, and evidence of leaks.</p>	<p>a. Chattering detected.</p> <p>b. Any damage, loose, or leaking component; Class III leak exists.</p>
13	BEFORE	Windshield Wipers & Washer Bottle	<p>a. Check for proper operation.</p> <p>b. Check fluid level in windshield washer bottle.</p> 	<p>a. Wiper motor inoperable.</p>
14	BEFORE	Seat Belt	<p>Check seat belt for wear, tears, and condition of locking device.</p>	<p>Seat belt worn, damaged, or inoperable.</p>

Table 5-1. Operator Preventive Maintenance Checks and Services Continued

ITEM NO.	INTERVAL	ITEM TO BE CHECKED OR SERVICED	PROCEDURE	NOT FULLY MISSION CAPABLE IF
	B			
15	BEFORE	Fuel Tank and Lines	Inspect fuel tank and lines for damage, security and evidence of leaks.	Any fuel system component damaged, loose, or leaking; Class II leak exists.
16	BEFORE	Fuel Water Separator	<p>Drain water and sediment from fuel-water separator as follows:</p> <ol style="list-style-type: none"> a. Open fuel filter/fuel-water separator access panel located in right rear wheel well. b. Loosen valve on fuel-water separator four complete turns until valve drops down one inch. Drain water and sediment until clear fuel is visible. <p style="text-align: center;">CAUTION Do not overtighten valve as it may be damaged.</p> <ol style="list-style-type: none"> c. Tighten to close drain valve. Then close access panel under wheelwell. <div style="display: flex; justify-content: space-around; align-items: center;">   </div>	

Table 5-1. Operator Preventive Maintenance Checks and Services Continued

ITEM NO.	INTERVAL	ITEM TO BE CHECKED OR SERVICED	PROCEDURE	NOT FULLY MISSION CAPABLE IF
	B			
17	DURING	Backup Alarm	Check for proper operation.	Backup alarm inoperable.
18	DURING	Main Control Panel Gages	<p>Check all main control panel gages for operation and proper readings as follows:</p> <p>a. OIL PRESS gage. Normal gage reading is 10 psi at idle. (35 psi at high idle and 85 psi at maximum governed speed)</p> <p>b. WATER TEMP gage. Normal gage reading is in green area.</p> <p>c. Converter OIL TEMP gage. Normal gage reading is in green area.</p> <p>d. Voltmeter (BATTERY) gage. Normal reading is 12 to 14 volts.limits.</p>	<p>a. Oil pressure lower than 10 psi.</p> <p>b. Gage reads in red area.</p> <p>c. Gage reads in red area.</p> <p>d. Gage reads outside of acceptable</p>
19	DURING	Brakes, Service & Parking	<p>NOTE Ensure outriggers are retracted.</p> <p>a. Park brake. With park brake lever applied, check for forward and reverse motion of vehicle.</p> <p>b. Service brakes. Check/listen for noise and stopping ability with crane moving slowly (in either direction) when depressing service brake pedal.</p>	<p>a. Any vehicle movement with park brake applied.</p> <p>b. Chattering, grinding, or inability to stop.</p>

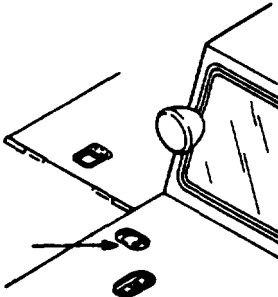
Table 5-1. Operator Preventive Maintenance Checks and Services Continued

ITEM NO.	INTERVAL	ITEM TO BE CHECKED OR SERVICED	PROCEDURE	NOT FULLY MISSION CAPABLE IF
	B			
20	DURING	Control Levers & Linkage	<p>SAFETY & LOCKING DEVICES</p> <p>Check for proper operation of all control levers and pedals. Verify that all controls operate without binding.</p>	Any control lever or pedal fails to operate.
21	DURING	Swing Brake	Check for proper operation of automatic swing brake.	Superstructure continues to move with swing lever in neutral position. Chattering, grinding, or inability to stop.
22	DURING	Antitwo-Block System	<p>CAUTION</p> <p>Do not allow the hook block to contact the lower boom nose sheave.</p> <p>Check for proper operation of the antitwo-block system by slowly raising the empty hook block until it contacts weight suspended from boom nose. Verify that hoist cannot be raised.</p>	Antitwo-block system inoperable
23	DURING	Steering	Check steering for smooth and proper operation.	Steering wheel binds or turns rough.
24	WEEKLY	Battery	<p>WARNING</p> <p>Do not smoke or allow flame or spark in the vicinity while checking the battery. The battery generates hydrogen, a highly explosive gas.</p>	

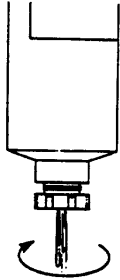
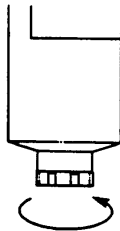
Table 5-1. Operator Preventive Maintenance Checks and Services Continued

ITEM NO.	INTERVAL	ITEM TO BE CHECKED OR SERVICED	PROCEDURE	NOT FULLY MISSION CAPABLE IF
	B			
25	WEEKLY	Battery - Continued	<p>a. Inspect battery terminals, cables, and clamps for security, damage, and corrosion.</p> <p>b. Using multimeter set for volts DC, check charge state of battery. Battery is fully charged at 12.71 Vdc.</p>	<p>a. Battery terminals, cables, or clamps loose, damaged, or corroded.</p> <p>b. Battery charge below 11 Vdc.</p>
		Brake Master Cylinder	<p>a. Check brake fluid level in brake master cylinder.</p> <p>b. Inspect brake master cylinder, brake fittings, tubes, and flexible hoses for damage, security, and evidence of leaks.</p>	<p>a. Brake fluid is low in brake master cylinder.</p> <p>b. Any brake line, hose, or fitting damaged, loose, or leaking; Class I leak exists.</p>
26	WEEKLY	Counterweight	 <p>Inspect counterweight for cracked or broken welds.</p>	Excessive cracks (more than two detected).
27	WEEKLY	Hydraulic Lines, Hoses, and Fittings	Inspect all hydraulic lines, hoses, and fittings for damage, security, and evidence, of leaks.	Any hydraulic line, hose, or fitting damaged, loose, or leaking.

Table 5-1. Operator Preventive Maintenance Checks and Services Continued

ITEM NO.	INTERVAL	ITEM TO BE CHECKED OR SERVICED	PROCEDURE	NOT FULLY MISSION CAPABLE IF
	B			
28	WEEKLY	Fan Belts	Inspect fan belt for loose, broken, cracked, or frayed condition. Belt should deflect approximately 1/2 in. at midspan between pulleys.	Damaged or loose.
29	MONTHLY	Hydraulic Cylinders and Valves	Inspect all hydraulic cylinders for damage, security, and evidence of leaks. Check for cracked or broken valve/cylinder bodies and mounting structures including worn, loose, or missing pivot pins and other attaching hardware.	Cracks or broken components; loose or missing attaching hardware; Class III leaks exist.
30	MONTHLY	Boom	a. Inspect boom for cracked or broken welds and bends/distortion of boom sections. b. Inspect boom wear pads for damage, wear, security, and lack of lubrication. pads.	a. Cracked or broken welds or distortion noted. b. Worn, damaged, loose, or unlubricated boom wear
31	MONTHLY	Exhaust System	Inspect muffler, exhaust pipes, and clamps for damage, security, and corrosion.	Any exhaust system component damaged, loose, or corroded.

5-3. OPERATING PROCEDURES.**5-3.1 Normal Engine Starting.****WARNING**

Before starting the engine, ensure the parking brake is applied.

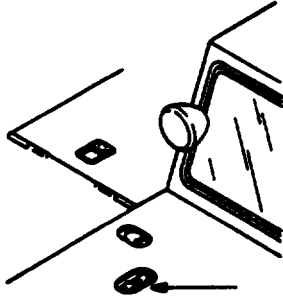
CAUTION

Never crank the engine for more than 30 seconds during an attempted start. If the engine fails to start after 30 seconds, allow the starter motor to cool for approximately two minutes before attempting another start.

NOTE

The engine will not crank unless the 1-2-D-N-R lever (11, Figure 5-1) is in the neutral (N) position.

- (a) Turn the IGNITION switch (28) to START and release immediately when the engine starts.
- (b) Check engine instruments for proper indications.

CAUTION

If oil pressure and/or temperature indicator(s) do not display proper readings, shut down the engine and correct the malfunction before resuming operation.

- (c) Allow the engine and hydraulic oil to warm up at least five minutes before applying a load.

NOTE

Gauge readings are given as a guide only. Readings may be slightly higher or lower depending on the individual engine condition. If in doubt, refer to the applicable engine service or operation manual.

5-3.2 Cold Weather Starting.

CAUTION

Avoid overloading the air intake manifold with highly volatile starting fluid while attempting to start the engine using the COLD START button (6, Figure 5-1). Do not attempt more than three consecutive cold weather starts without first allowing the starting fluid in the air intake manifold to dissipate. Failure to follow this caution could result in overloading the air intake manifold with starting fluid which could result in a minor explosion and damage to the engine.

NOTE

The correct grade of oil for the prevailing temperature should be used in the crankcase to prevent hard cranking.

NOTE

Diesel fuel should have a pour point of 10°F (-12°C) less than the lowest expected temperature. In case of emergency, white kerosene may be added to the fuel to bring the pour point down to the required temperature to prevent clogging of filters and small passages by wax crystals. The addition of kerosene is NOT recommended for general use. If low temperatures are ONLY expected at startup, it is advisable to use starting aids such as preheating, starting fluid metering equipment, or starting fluid spray application into the air cleaner intake.

- a. To start the engine, place the IGNITION switch (28, Figure 5-1) to the START position and push the COLD START button (6) for two seconds and release.
- b. If the engine does not start within 30 seconds, allow the starter to cool for approximately two minutes and repeat the procedure.

5-3.3 Shutdown Procedure.

- a. Allow the engine to operate at fast idle speed for approximately five minutes to avoid high internal heat rise and allow for heat dissipation.

NOTE

If the **IGNITION** switch (28, Figure 5-1) does not shut down the engine, turn the fuel off at the fuel supply shutoff valve located at the fuel tank.

- b. Position the **IGNITION** switch (28) to the OFF position.

5-3.4 Crane Travel Operation. The crane is primarily designed for yard and close proximity areas. Design and application intent precludes operation on public highways; however, many jurisdictions permit limited travel under controlled conditions. Consult local vehicular codes and regulations in your area.

WARNING

Do not travel with an empty hook in a position where it can swing freely. Always secure an empty hook to the tiedown provided on the front of the crane (see cover illustration).

WARNING

Avoid holes, rocks, extremely soft surfaces, and any other obstacles which might subject the crane to undue stresses or possible overturn.

WARNING

On open ground, tow or pull only on the pintle hooks or lift/tow lugs.

CAUTION

For extended travel, check the cold tire pressure prior to start. (Refer to tire inflation chart in Appendix E, sheet 9.) Regardless of ambient temperature, after every two hours of travel time, stop and allow the tires to cool off for at least a 30 minute period. At destination, the tires must be allowed to cool to ambient temperature before crane lifting on rubber.

CAUTION

Do not drive the crane with the lift cylinder bottomed. Position the boom to just above horizontal.

CAUTION

Should the crane become mired down, use a tow truck or tractor to free the vehicle. Severe damage to the transmission or axles may occur if the operator attempts to free the crane unassisted.

CAUTION

If the crane is mired down, use the lugs to pull or tow. There are two lift/tow lugs available on each end of the crane. When using these lugs, always tow or pull using both lugs.

5-3.5 Driving the Crane. The following operating conditions should be strictly adhered to before moving the crane. Procedures for accomplishing the following can be found in the various Sections of this manual.

- a. Ensure the boom is fully retracted. Refer to paragraph 5-3.15.
- b. Swing the boom over-the-front and lower the boom to just above horizontal. Refer to paragraph 5-3.11.
- c. Remove the hook block and stow securely before traveling or ensure the hook block is properly secured to the tie down provided for that purpose. Refer to illustration of crane on front cover.
- d. Ensure the outriggers are fully retracted. Refer to paragraph 5-3.10.
- e. Apply foot brake pedal (8, Figure 5-1) then release parking brake by pulling up on lever (18).
- f. Using 1-2-D-N-R lever (11, Figure 5-1), select D (Drive forward) or R (reverse).
- g. Release foot brake pedal (8, Figure 5-1) and depress foot throttle pedal (7).
- h. Steer crane in a manner similar to that of an automobile.
- i. To stop, release foot throttle pedal (7, Figure 5-1) and depress foot brake pedal (8).

NOTE

If there is a hydraulic power failure, the crane can still be steered, because the steering control valve acts as a pump when the steering wheel is turned. However, steering in this manner is very difficult. If this failure should occur, immediately bring the crane to a safe stop and proceed with immediate repairs or replacement.

5-3.6 General Crane Operation. The control lever operation for crane functions is standard, i.e., the closer the lever is to neutral (center), the slower the system responds. This applies to both forward and rear movement of the applicable lever. The control lever should be returned to neutral to hold the load.

CAUTION

Never feather the hoist control to hold the load.

NOTE

Always operate the control lever with slow, even pressure.

5-3.7 Functional Check. After the crane has been readied for service, a functional check of all craning functions (with no load applied) should be performed.

WARNING

Carefully read and become familiar with all crane operating instructions before attempting to operate the crane.

- a. Operate the engine at or near the governed RPM during performance of all crane functions.
- b. Extend and set the outriggers. Refer to paragraph 5-3.9.
- c. Raise, lower, and swing the boom right and left a minimum of 45 degrees. Refer to paragraphs 5-3.11, 5-3-12, and 5-3-13.
- d. Telescope the boom in and out. Refer to paragraphs 5-3.14 and 5-3-15.
- e. Raise and lower the hoist cable a few times at various boom lengths. Check for kinks in the cable. Refer to paragraphs 5-3.16 and 5-3.17.

5-3.8 Using Load Chart.

NOTE

One of the most important tools of every crane is the load chart found in the operator's cab. Refer to Figure 5-2 as required.

The load chart contains a large amount of information, which must be thoroughly understood by the operator.

The load chart contains a Range Diagram, Lifting Area Diagrams, one On Outriggers Chart, and one On Rubber Capacity Chart.

The capacity charts are divided into capacities limited by structural strength and capacities limited by stability. This is shown by the bold line across the chart. Capacities above the line are limited by structural strength and capacities below the line are limited by crane stability.

Another important section of the load chart is the range diagram. The range diagram illustrates the tip height which can be achieved at each boom length, angle, and radius. If the operator knows the radius required for a specific lift and the tip height necessary, he can calculate the required boom length and angle needed for the lift. He then checks the capacity chart for the specific boom length and radius to find out if the crane is capable of performing the lift safely. Or, on the other hand, if the boom length and angle are known, the radius can be determined from the range diagram.

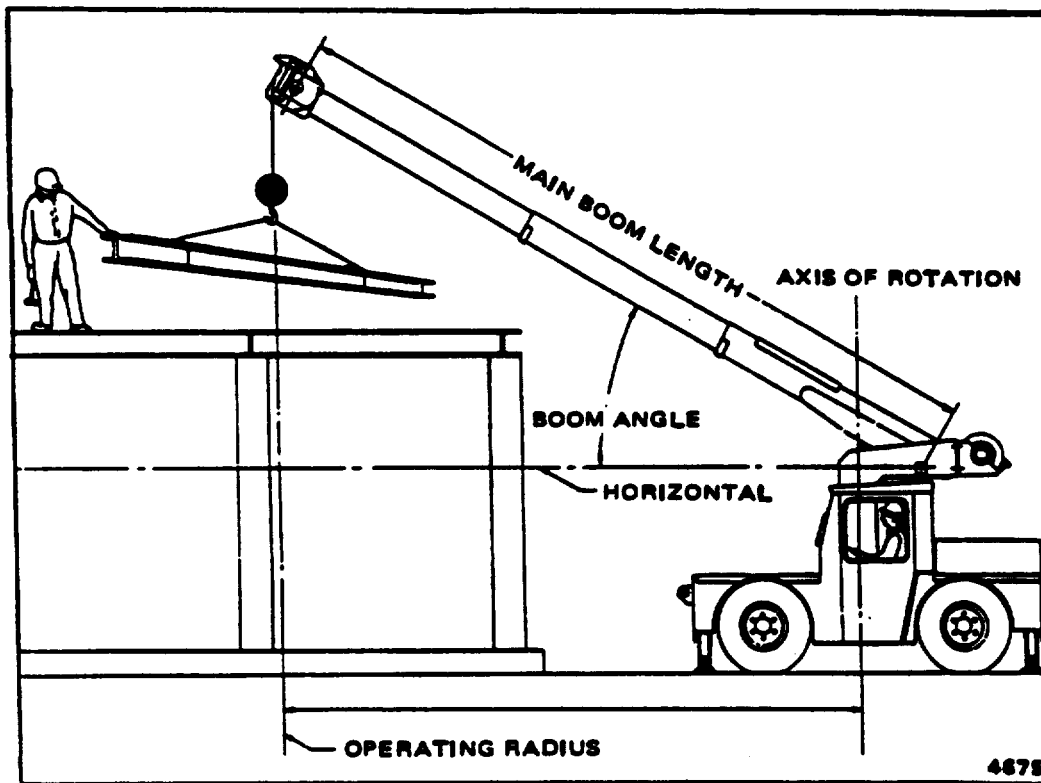

Figure 5-2. Terms to Know When Using Load Chart

A lifting area diagram is included as part of the load chart to describe over side, over rear, and over front lifting areas. An examination of the lifting area diagram shows that the locations of the outriggers in the fully extended position are used to mark the boundaries of the lifting areas.

The last major portion of the load chart is the section concerning notes to lifting capacities. Be sure to read all notes carefully so you understand what each one means. The load chart also gives weight reductions for Grove load handling devices such as hook blocks, headache balls, boom extension section, etc., which must be taken into consideration as part of the load. Remember, any other load handling devices such as chains, slings, or spreader bars must also be considered, and the weight of these devices must be added to the weight of the load.

NOTE

The information in the following paragraph is an example of how to compute a lift, but the numbers used in the example may not coincide with the load chart in the cab.

To understand the uses of the load chart, a typical example of a lifting problem is offered. Determine whether or not the lift can be made safely. The problem is to lift an air conditioning unit weighing 2,350 lbs (1,066 kg), which is secured by bolted wood blocking and located between aisles of outside storage. The air conditioning unit is to be loaded on a flat bed truck located in an open loading area 50 ft (15.24 m) from the storage area. Further, the distance between the aisles prevent performing the lifting operation with the crane on outriggers. The crane is equipped with the 10.6 to 24 ft (3.0 to 7.3 m) three-section boom. By measuring the center of the load, in relation to the center line of rotation of the crane, the radius is determined to be 18 ft (5.4 m). Checking the load charts in the crane cab indicates that 3,000 lbs (1,360.8 kg) may be safely lifted at an 18 ft (5.4 m) radius.

NOTE

The weights of all load handling devices are considered part of the load lifted and suitable allowances for them should be made.

A sling and spreader bar are also required to perform the lift; therefore, it is mandatory that the combination weight be added to the unit being lifted. The new total weight is now 2,425 lbs (1,000 kg). A double check of the load chart reveals the lift may still be made safely. Although this lift may be performed with reasonable ease, a good craning practice may be exercised by extending and setting the outriggers if equipped when hoisting the load onto the flat bed truck.

5-3.9 Setting the Outriggers.**WARNING**

The outriggers must be set before any other operation of the crane is attempted, unless lifting on rubber. Failure to comply could result in injury or death.

- a. Position OUTRIGGER control lever (9, Figure 5-1) to DOWN.
- b. Position OUTRIGGER SELECTOR switches (21 and 22) to the desired position(s) and hold until the outriggers are fully extended, tires clear the ground, and the crane is level as indicated by the level indicator, Figure 5-3.
- c. Return OUTRIGGER control lever (9) and OUTRIGGER SELECTION switches (21 and 22) to their neutral positions.

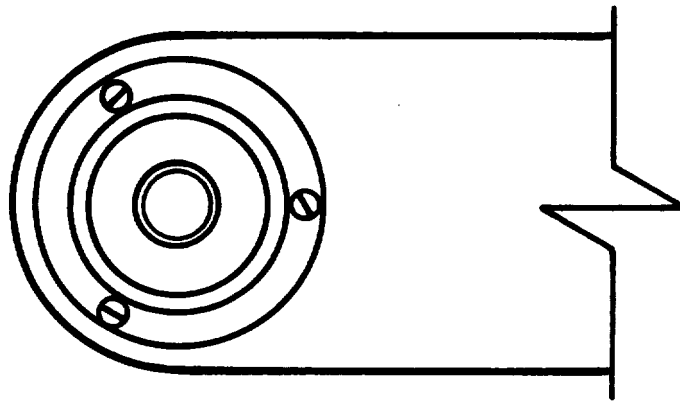

Figure 5-3. Crane level Indicator

5-3.10 Stowing the Outriggers.

- a. Position OUTRIGGER control lever (9, Figure 5-1) to UP.
- b. Position OUTRIGGER SELECTION switches (21 and 22) to the desired position(s) and hold until the outriggers are fully retracted.
- c. Return OUTRIGGER control lever (9) and OUTRIGGER SELECTION switches (21 and 22) to their neutral positions.

5-3.11 Swinging the Boom.**WARNING**

Before initiating any swing operations, make certain the area in the swing path of the hook block and/or load as well as the tail swing area, is clear of all obstructions. Failure to comply could result in injury or death.

WARNING

When swinging the load from over-the-front to over-the-side of the crane, refer to the over-the-side load chart to make certain the applicable capacity is not exceeded. Traveling with any load over-the-side is prohibited.

CAUTION

Never push or pull the SWING control lever (31, Figure 5-1) through neutral to the opposite direction to stop swing motion.

NOTE

Always operate the control lever with a slow, even pressure.

- a. To swing boom RIGHT, push SWING control lever (31) forward (away from the operator). To swing LEFT, pull back (toward the operator).
- b. To stop boom swing, return SWING control lever (31) to its neutral position which automatically sets the swing brake.

5-3.12 Elevating the Boom.**WARNING**

Before elevating the boom, ensure the area above and beneath the boom is clear of all obstructions and personnel.

- a. To elevate boom, pull LIFT control lever (10, Figure 5-1) back (toward the operator) to the UP position, and hold until the boom reaches the desired elevation angle.
- b. To stop boom elevation, return LIFT control lever (10) to its neutral position.

5-3.13 Lowering the Boom.**WARNING**

Before lowering the boom, make certain the area beneath the boom is clear of all obstructions and personnel.

WARNING

Long cantilever booms can create a tipping condition even when unloaded and in an extended and lowered position.

WARNING

When lowering the boom, lower the cable at the same time to prevent two-blocking the boom nose and the hook block.

WARNING

The closer the load is carried to the boom nose, the more important it becomes to let out hoist cable as the boom is lowered.

- a. To lower boom, push LIFT control lever (10, Figure 5-1) forward (away from the operator) to DOWN position and hold until boom is lowered to desired position.
- b. To stop boom, return LIFT control lever (10) to its neutral position.

5-3.14 Extending the Boom.**WARNING**

When extending the boom, let out cable simultaneously to prevent two-blocking the boom nose and hook block.

WARNING

Check the load chart for maximum load at given radius, boom angle, and length before extending boom with a load.

- a. To extend boom, push TELE control lever (30, Figure 5-1) (away from the operator) to OUT position and hold until the boom extends to desired length.
- b. To stop boom extension, return TELE control lever (30) to its neutral position.

5-3.15 Retracting the Boom.

WARNING

When retracting the boom, the load will lower unless the hoist cable is taken in simultaneously.

- a. To retract boom, pull TELE control lever (30, Figure 5-1) (toward the operator) to IN position and hold until boom retracts to desired length.
- b. To stop boom, return TELE control lever (30) to its neutral position.

5-3.16 Lowering Hoist Cable.

WARNING

Before lowering or raising the load, ensure the area beneath the load is clear of all obstructions and personnel.

CAUTION

When starting or stopping the hoist, do not jerk the HOIST control lever (5, Figure 5-1). Jerking the lever causes the load to bounce, which could result in possible damage to the crane.

NOTE

When the load is stopped at the desired height, the automatic brake will engage and hold the load as long as the control lever remains in neutral.

- a. To lower hoist cable, push HOIST control lever (5) forward (away from the operator) to DOWN position and hold until the hook or load is lowered to the desired height.
- b. To stop hoist cable, return HOIST control lever (5) to its neutral position. This automatically sets the hoist brake.

5-3.17 Raising the Hoist Cable.

- a. To raise hoist cable, pull the HOIST control lever (5, Figure 5-1) back (toward the operator) to UP position and hold until hook or load is raised to desired height.
- b. To stop hoist cable, return HOIST control lever (5) to its neutral position.

5-3.18 Emergency Load Lowering Procedures. The following procedure will be used to lower a load suspended in the air after a major powertrain or hydraulic system failure after which, the hoist has become inoperable. This procedure will provide hydraulic pressure to override the hoist brake mechanism allowing the load to slowly lower to the ground.

LATER

5-3.19 Recommended Crane Shutdown Procedures. The following procedure will extend the service life of various crane components, reduce vandalism and accidents during crane shutdown periods or anytime the crane is left unattended.

WARNING

Never park the crane near holes, or on rocky or extremely soft surfaces. This may cause the crane to overturn, resulting in injury to personnel.

- a. Remove load from hook block.
- b. Remove or stow all jibs or boom extensions.
- c. Fully retract the boom.
- d. Lower boom to normal travel position.
- e. Retract all outriggers.
- f. Park crane on a flat stable surface.
- g. Apply parking brake and chock wheels.
- h. Ensure all operating controls are in their neutral positions.

CAUTION

Allow the engine to idle from 3 to 5 minutes after a full-load operation before shutting it down. This will allow the engine to cool down gradually and uniformly.

- i. After cool down period, shut down engine by turning IGNITION switch (28, Figure 5-1) to OFF.
- j. Remove ignition key.
- k. Close and latch sliding cab door window. Then close and lock cab door.
- l. Close and secure all frame access covers.

5-3.20 Operating Cab Heater.

NOTE

The cab heater has air ducts that release air both under the operator's seat and above the main control panel (to defrost the windshield). The air flow through both ducts is controlled by the FAN knob.

- a. Turn FAN knob (19, Figure 5-1) to control the speed of the fan.
- b. Pull air TEMP control knob (20) for warm air and push the knob in for cool air.

SECTION 6

MAINTENANCE INSTRUCTIONS

6-1. LUBRICATION INSTRUCTIONS.

6-1.1 **General.** Following the designated lubrication procedures is important in ensuring maximum crane lifetime and utilization. The procedures and lubrication charts in this section include information on the types of lubricants used, the location of the lubrication points, the frequency of lubrication, and other information.

The service intervals specified are for normal operation where moderate temperature, humidity, and atmospheric conditions prevail. In areas of extreme conditions, the service periods and lubrication specifications should be altered to meet existing conditions. For information on extreme condition lubrication, contact your local service representative or Grove Customer Services, Chambersburg, Pennsylvania.

CAUTION

Chassis grease lubricants must not be applied with air pressure devices as this lubricant is used on sealed fittings.

CAUTION

The multipurpose grease used during manufacture is lithium based. Use of a non-compatible grease could result in damage to equipment.

Specific recommendations of brand and grade of lubricants are not made here due to regional availability, operating conditions, and the continual development of improved products. Where questions arise, refer to the component manufacturer's manual and a reliable supplier.

6-1.2 **Lubrication Symbols.** Symbols and descriptions used throughout this section are as follows:

EP-MPG. Extreme Pressure Multipurpose Grease. This is a lithium soap base grease with a high load carrying capacity. The following properties are recommended.

Timken OK Load	40 lb (18.1 kg) minimum
Dropping Point	350°F (177°C) minimum
Oil Viscosity	75 SUS minimum at 210°F (99°C)
Water Resistance	Excellent

Under normal operating conditions, the following consistency grades are recommended.

- NLGI No. 0 or 00 for -0°F (-18°C) temperatures
- NLGI No. 1 or 2 for normal ambient temperatures
- NLGI No. 2 or 3 for temperatures over 100°F (38°C)

Unless otherwise specified, an EP-MPG containing molybdenum disulfide may be used.

EPGL-5. Extreme Pressure Multipurpose Gear Lubricant. This gear lubricant is compounded to achieve high load carrying capacity and meet the requirements of either API-GL-5 or MIL-L-2105C. Unless otherwise specified, SAE 80W-90 viscosity may be used for year-round service. Low temperature usage is restricted as follows:

SAE Viscosity Designation	Minimum Ambient Temperature
75W	-40°F (-40°C)
80W	-15°F (-26 °C)
85W	+10°F (-12°C)
90	+20°F (-7°C)
140	+40°F (+5°C)
250	+50°F (+ 10°C)

EPGL-5H. Extreme Pressure Multipurpose Gear Lubricant. This gear lubricant is compounded to achieve high load carrying capacity and meet the requirements of either API-GL-5 or MIL-L-2105C. Unless otherwise specified, SAE 85W-140 viscosity may be used for year-round service.

EO. Engine Oil. Internal combustion engine lubricating oils are classified primarily by viscosity characteristics and on performance as determined by a series of tests called MS test sequences. Lubricants marketed for heavy-duty service consist of refined crude oil containing additives compounded to meet the desired engine performance levels. Use only good quality oil provided by a reputable supplier in accordance with the service classification and viscosity requirements specified by the engine service manual.

ATF. Automatic Transmission Fluid. ATF shall meet the latest requirements for General Motors Dexron II specification.

SBF. Silicone Brake Fluid. A silicone-based hydraulic brake fluid, conforming to MIL-B-46176, for use in hydraulic brake systems at ambient temperature ranging from -67° to +131°F (-55° to +55°C). It is intended to be used in braking systems fitted with cups and seals made from natural rubber, buna 5, polychloroprene or ethylene proplene diene monomer.

HYDO. Hydraulic Oil. Oil in a hydraulic system serves as the power transmission medium, system lubricant, and coolant. Selection of the proper oil is essential to ensure satisfactory system performance and life. (See Hydraulic Oil Recommendations, paragraph 6-1.3.)

HYDO may be further described using a suffix as follows:

- RO - Rust and oxidation inhibited oil
- AW - A premium oil with antiwear additive
- LT - Low temperature hydraulic oil

WPG. Water Pump Grease. This is a multi-purpose high pressure lithium soap base grease. The following properties are recommended.

Dropping Point	240°F (171°C) minimum
Water Resistance	Excellent
NLGI Grade	No. 2

WRL. Chemically neutral Wire Rope Lubricant used to prevent corrosion and reduce wear caused by internal friction. OGL is sometimes suitable. WRL should be selected and applied in accordance with operating conditions and recommendations of a reputable lubricant supplier. (See Wire Rope Lubrication, paragraph 6-1.6.)

6-1.3 Hydraulic Oil Recommendations. New cranes come from the factory with Kendall Hyken 052, a type of hydraulic fluid commonly known as Tractor Hydraulic Fluids. Tractor Hydraulic Fluids are intended to provide chatter-free lubrication of wet brakes and wet clutches in addition to good gear lubrication and hydraulic performance.

Factory fill oil meets the optimum viscosity requirements through a temperature range from -5° to 210°F (-21° to 99°C). When replenishment of the oil becomes necessary, or when replacement of the oil is required as a result of contamination or operation outside the recommended temperature range for the factory fill oil, the following types of oil are suitable under most operating conditions.

- Tractor Hydraulic Fluids of suitable viscosity.
- Good quality anti-wear hydraulic oils of suitable viscosity and specifically formulated to provide chatter-free operation of wet brakes.

The most important factors in selecting an oil for hydraulic service are:

- Viscosity.
 - Anti-wear additives.
- a. Viscosity. The oil must have proper viscosity to provide a lubricating film at system operating temperature. Oil viscosity is important because it has a direct bearing on efficient transmission of power. An oil must flow readily through the system with a minimum of pressure and flow loss. Positive lubrication depends on viscosity. The oil must be sufficiently light to get between the components machined surfaces, and maintain a lubricating film at system operating temperatures. Cold weather start-up procedures should allow for a gradual warm-up until the oil reaches a reasonably fluid state.

Oil too light may cause the following conditions in the system.

- Excessive leakage.
- Lower volumetric efficiency of the pump.
- Increased component wear.
- Loss of system pressure.
- Lack of positive hydraulic control.
- Lower overall efficiency.

Oil too heavy may cause the following conditions in the system.

- System pressure drop.
- Increases system temperature.
- Sluggish system operation.
- Low mechanical efficiency.
- Higher power consumption.

The following oil viscosity characteristics are recommended.

- 80 to 180 SUS optimum at system operating temperature
- 60 SUS minimum at system operating temperature
- 7500 SUS maximum at starting temperature
- 90 Viscosity Index (VI), minimum
- Pour point at least 20°F (11°C) below start-up temperature

The following grades will usually meet the above viscosity requirements.

SAE Viscosity Designation	Temperature
5W-20	-10° to 180°F(-23° to 82°C)
10W	+10° to 180°F(-12° to 82°C)
10W30	+ 10° to 210°F(-12° to 99°C)

- b. Arctic Conditions. (Below 0°F (-18°C). In general, petroleum-based fluids developed especially for low temperature service may be used with satisfactory results. However, certain fluids, such as halogenated hydrocarbons, nitro hydrocarbons, and phosphate ester hydraulic fluids, might not be compatible with hydraulic system seals and wear bands. If you are in doubt about the suitability of a specific fluid, check with your authorized Grove distributor or Grove Customer Services.

Regardless of temperature and oil viscosity, always use suitable start-up procedures to ensure adequate lubrication during system warm-up.

- c. Antiwear Additives. Excessive wear in the system may cause a loss in volumetric efficiency and may cause shutdowns for maintenance. An efficient antiwear oil protects the components against rusting, resists oxidation, and helps prevent wear.

6-1.4 **Lubrication Points.** A regular frequency of lubrication must be established for all lubrication points. Normally, this is based on component operating time. The most efficient method of keeping track of lube requirements is to maintain a job log indicating crane usage. The log must use the engine hourmeter to ensure coverage of lube points that will receive attention based on their readings. Other lubrication requirements must be made on a time basis, i.e., weekly, monthly, etc.

All oil levels are to be checked with the crane parked on a level surface in transport position, and while the oil is cold, unless otherwise specified.

On plug-type check points, the oil levels are to be at the bottom edge of the check port.

On all hoists with a check plug in the drum, the fill plug shall be directly on top of the hoist, and the check plug level.

All grease fittings are SAE standard unless otherwise indicated. Grease non- sealed fittings until grease is seen extruding from the fitting. One ounce (28 grams) of EP-MPG equals one pump on a standard 1.0 lb (0.45 kg) grease gun.

Over lubrication on non-sealed fittings will not harm the fittings or components, but under lubrication will definitely lead to a shorter lifetime.

On sealed U-joints, care must be exercised to prevent rupturing seals. Fill only until expansion of the seals first becomes visible.

Unless otherwise indicated, items not equipped with grease fittings, such as linkages, pins, levers, etc., should be lubricated with oil once a week. Motor oil, applied sparingly, will provide the necessary lubrication and help prevent the formation of rust. An Anti-Seeze compound may be used if rust has not formed, otherwise the component must be cleaned first.

Grease fittings that are worn and will not hold the grease gun, or those that have a stuck check ball, must be replaced.

Where wear pads are used, cycle the components and relubricate to ensure complete lubrication of the entire wear area.

6-1.5 **Lubrication Chart.** The following describe the lubrication points and gives the lube type, lube interval, lube amount, and application of each. Each lubrication point is numbered, and this number corresponds to the index number shown on the Lubrication Chart, Figure 6-1.

<u>Index No.</u>	<u>Description/Lube Requirement</u>
1	<u>Hook Block Swivel Bearing.</u> Lube Type - EP-MPG Lube Interval - Weekly Lube Amount - Until grease extrudes Application - 1 grease fitting

- 2 **Hook Block Sheave.**
 Lube Type - EP-MPG
 Lube Interval - Weekly
 Lube Amount - Until grease extrudes
 Application - 1 grease fitting

- 3 **Boom Wear Pads.**
 Lube Type - EP-MPG
 Lube Interval - Weekly
 Lube Amount - Thoroughly coat the area the wear pad moves on
 Application - By brush

- 4 **Boom Nose Sheaves.**
 Lube Type - EP-MPG
 Lube Interval - Weekly
 Lube Amount - Until grease extrudes
 Application - 1 grease fitting per sheave

- 5 **Telescope Cylinder Wear Pads.**
 Lube Type - EP-MPG
 Lube Interval - Weekly
 Lube Amount - Thoroughly coat the area the wear pad moves on
 Application - By brush

- 6 **Boom Pivot Shaft.**
 Lube Type - EP-MPG
 Lube Interval - Daily
 Lube Amount - Until grease extrudes
 Application - 2 grease fittings, one on each side of the pivot shaft

- 7 **Lift Cylinder.**

NOTE

When greasing the lift cylinder and boom pivot shafts, better distribution of grease within the shafts is obtained if the weight of the boom is removed from the shafts.

Lube Type - EP-MPG
 Lube Interval - Daily
 Lube Amount - Until grease extrudes
 Application - 2 grease fittings, one on each side of lift cylinder bushing

- 8** **Hoist.**
- Lube Type - EPGL-5H
Lube Interval - Monthly
Lube Amount - Capacity 2.0 qt (1.8 L)
Application - With crane level, position the drum so one of the plugs is directly at the top
- 9** **Engine.**
- Lube Type - E015W/40
Lube Interval - Check daily, drain per Engine Service Manual
Lube Amount - See Engine Service Manual TM 10-3950-672-24-3
Application - See Engine Service Manual TM 10-3950-672-24-3
- 10** **Turntable Bearing.**
- Lube Type - EP-MPG
Lube Interval - Weekly
Lube Amount - Until grease extrudes the whole circumference on the bearing
Application - 1 grease fitting. Walk around as the superstructure is being rotated. Ensure the entire bearing is lubed.
- 11** **Turntable Gear Reducer.**
- Lube Type - EPGL-5H
Lube Interval - Weekly, drain 1 st time after 250 hrs and every 500 hrs or 12 months thereafter
Lube Amount - Capacity - 40 oz (1.18 L)
Application - Fill to level on dipstick
- 12** **Turntable Gear and Pinion.**
- Lube Type - EP-MPG
Lube Interval - Weekly
Lube Amount - Coat all teeth
Application - Brush on
- 13** **Tie Rod End and Links.**
- Lube Type - EP-MPG
Lube Interval - Weekly
Lube Amount - Until grease extrudes
Application - 1 grease fitting on each side of the tie rod, and 1 grease fitting on each spindle

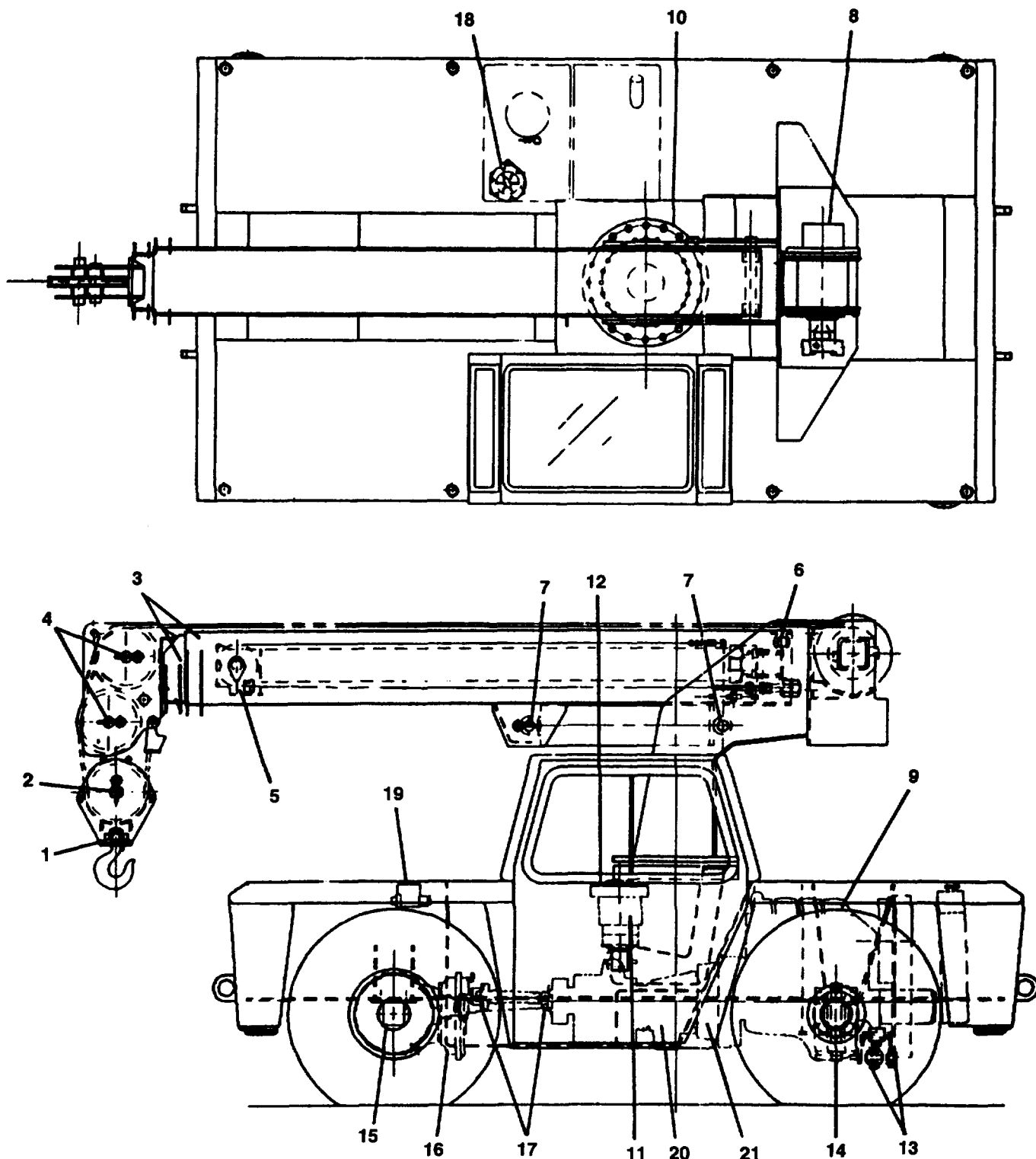

Figure 6-1. Lubrication Chart

Legend

- | | |
|------------------------------|---------------------------------|
| 1. Hook Block Swivel Bearing | 11. Turntable Gear Reducer |
| 2. Hook Block Sheave | 12. Turntable Gear and Pinion |
| 3. Boom Wear Pads | 13. Tie Rod End and Links |
| 4. Boom Nose Sheaves | 14. King Pin Bearings |
| 5. Telescope Cylinder | 15. Wheel Bearings (Drive Axle) |
| 6. Boom Pivot Shaft | 16. Differential |
| 7. Lift Cylinder | 17. Drive Line Joints |
| 8. Hoist | 18. Hydraulic Reservoir |
| 9. Engine | 19. Master Cylinder |
| 10. Turntable Bearing | 20. Transmission (Gearbox) |
| 21. Torque Converter | |

14 King Pins.

Lube Type - EP-MPG
 Lube Interval - Weekly
 Lube Amount - Until grease extrudes
 Application - 1 grease fitting on each side

15 Wheel Bearings (Drive Axle).

Lube Type - EP-MPG
 Lube Interval - Change whenever seals are replaced or when the brakes are relined
 Lube Amount - Until full
 Application - Clean and pack the bearings

16 Differential.

Lube Type - EPGL-5
 Lube Interval - Monthly
 Lube Amount - 14.0 pt (6.4 L)
 Application - Fill through the filler hole until lubricant is at bottom of filler hole

17 Drive Line Joints.

Lube Type - EP-MPG
 Lube Interval - Weekly
 Lube Amount - Until grease extrudes
 Application - 3 grease fittings

18 Hydraulic Reservoir.

Lube Type - HYDO
 Lube Interval - Weekly
 Lube Amount - (Total Capacity) 35 gal. (132.4 L)
 (Gauge Level Capacity) 30 gal. (113.5 L)

19 **Master Cylinder.**

Lube Type - SBF

Lube Interval - Weekly

Lube Amount - 6.0 oz (0.18 L)

Application - Gain access through the deck cover in front of the cab. Fill to top of reservoir.

20 **Transmission.**

Lube Type - DEXRON II, or equivalent

Lube Interval - Check daily with the transmission in N, engine at curb idle rpm, foot brakes applied, and crane on level surface. Move the transmission selector lever through D-N-R. Allow time in each range to engage the transmission, return to N, and apply parking brake fully. Do not turn off the engine during the fluid level check. At operating temperature (150° to 170°F [66° to 77°C]), the dipstick reading should have the fluid level on the dipstick is within the crosshatched area with the engine running at idle. If it should become necessary to check the fluid at room temperature (70° to 95°F [21° to 35°C]), the dipstick reading should have the fluid level on the dipstick between the two holes punched in the dipstick.

NOTE

For more information on fluid level checks and fluid conditions, refer to TM 10-3950-672-24-2.

Lube Amount - If a partial drain was done, add 5 qt (4.7 L) shallow pan or 6 qt (5.6 L) deep pan of fluid through the filler tube. Check the fluid. If a complete drain was done, the approximate refill capacity is 11.75 qt (11.2 L). The approximate dry capacity includes cooler and lines.

Application - Through the filler tube

6-1.6 **Wire Rope Lubrication.** Wire rope is lubricated during manufacturing so the strands, and individual wires in strands, may move and adjust as the rope moves and bends. A wire rope cannot be lubricated sufficiently during manufacture to last its entire life. Therefore, new lubricant must be added periodically throughout the life of a rope to replace factory lubricant which is used or lost.

The surface of some ropes may become covered with dirt, rock dust, or other material during their operation. This covering can prevent field applied lubricants from properly penetrating into the rope. Therefore, these ropes should be cleaned before being lubricated.

The lubricant applied should be light-bodied enough to penetrate to the core of the rope. Lubricant may be applied effectively by various methods. It may be dripped on, sprayed on, or put on by brushing, but in any case it should be applied at a place where the rope is being bent, such as at a sheave. It should be applied at the top of the bend, because at this point the strands are spread by bending and are more easily penetrated. The service life of rope will be directly proportional to the effectiveness of the method used and amount of lubricant reaching the working parts of the rope.

A proper lubricant must reduce friction, protect against corrosion, adhere to every wire and be pliable and not crack or separate when cold and yet not drip when warm.

Special lubricant can be applied at the factory to meet unusual conditions.

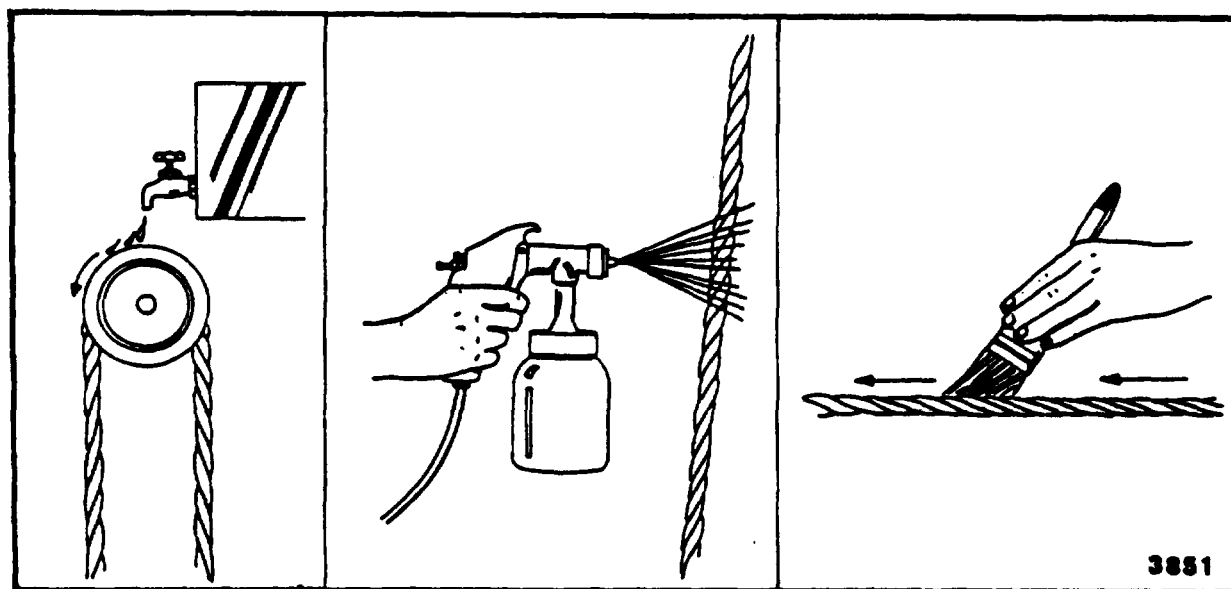

Figure 6-2. Wire Rope Lubrication

6-2. TROUBLESHOOTING.

SYMPTOM INDEX

Malfunction	Troubleshooting Procedures Page
-------------	---------------------------------------

ENGINE

Engine will not crank or cranks slowly	6-13
Engine hard to start or will not start - exhaust smoke present	6-14
Engine cranks, but will not start - no smoke from exhaust	6-14
Engine starts but will not keep running	6-15
Engine will not shut off	6-15
Rough idle, warm engine	6-15
Engine surges at idle	6-16
Low lubricating oil pressure	6-16
Lubricating oil pressure too high	6-16
Lube oil loss	6-17
Contaminated engine oil	6-17
Exhaust smoke excessive under load	6-17
Engine will not reach rated speed when loaded	6-17
Low power	6-18
Engine misfiring	6-18
Fuel knock	6-18
Excessive fuel consumption	6-19
Excessive vibration	6-19
Excessive engine noises	6-19
Fuel or oil leaking from exhaust manifold	6-20

COOLING SYSTEM

Coolant temperature above normal	6-20
Coolant loss	6-21
Coolant temperature below normal	6-21
Contaminated coolant	6-22

ELECTRICAL SYSTEM

Alternator not charging or insufficient charging	6-22
--	------

TRANSMISSION

Crane will not move or moves erratically (transmission failure)	6-23
Transmission oil temperature above normal	6-23

BRAKES

Brakes are poor or do not apply	6-23
---------------------------------------	------

HYDRAULIC SYSTEM

Hard to steer left and right	6-24
Slow or erratic operation of outrigger cylinders	6-24
Outrigger system will not activate	6-24
Outrigger system activates, but selected outrigger will not retract or extend and lower as desired	6-25
Boom raises or lowers erratically	6-25
Boom raises or lowers slowly	6-25
Boom will not raise or lower	6-26
Erratic operation of telescope cylinder	6-26
Telescope cylinder will not extend or retract	6-27
Hoist will not raise load	6-27
Hoist will not lower load	6-28
Slow or erratic hoist operation	6-28
Boom swing operations erratic in either direction	6-28
Swing brake system will not operate	6-29

Table 6-1 lists the common malfunctions which you may find during the operation or maintenance of the crane or its components. You should perform the tests/inspections and corrective actions in the order listed.

This manual cannot list all malfunctions that may occur, nor all test or inspections and corrective actions. If a malfunction is not listed or is not corrected by listed corrective actions, notify your supervisor.

Table 6-1. Operator Troubleshooting

MALFUNCTION	TEST OR INSPECTION	CORRECTIVE ACTION
1. <u>ENGINE WILL NOT CRANK OR CRANKS SLOWLY.</u>		
	Step 1.	Starting circuit connections loose or corroded.
		a. Inspect connections at starting motor. If tight and corrosion free, do step 2.
		b. Contact Organizational Maintenance to clean and tighten connections.
	Step 2.	Battery charge low.
		a. Contact Organizational Maintenance to charge/service batteries.

Table 6-1. Operator Troubleshooting (continued)

MALFUNCTION	TEST OR INSPECTION	CORRECTIVE ACTION
2.	<u>ENGINE HARD TO START OR WILL NOT START - EXHAUST SMOKE PRESENT.</u>	<p data-bbox="285 443 911 470">Step 1. Starting aid needed for cold weather.</p> <p data-bbox="477 506 1235 562">a. Use cold weather starting aid. Refer to paragraph 5-3.2. If engine does not start do step 2.</p> <p data-bbox="285 596 802 623">Step 2. Intake air system restricted.</p> <p data-bbox="477 659 1130 686">a. Inspect air cleaner inlet hood. If OK, do step 3.</p> <p data-bbox="477 722 1256 806">b. Contact Organizational Maintenance to remove intake hood and air filter element. Replace air filter element and clean intake hood.</p> <p data-bbox="285 842 704 869">Step 3. Fuel contaminated.</p> <p data-bbox="477 873 1252 930">a. Check fuel filter/water separator for contamination. Refer to PMCS in Section 5. If fuel OK, do step 4.</p> <p data-bbox="285 963 915 991">Step 4. Contact Organizational Maintenance.</p>
3.	<u>ENGINE CRANKS. BUT WILL NOT START- NO SMOKE FROM EXHAUST.</u>	<p data-bbox="285 1121 656 1148">Step 1. No fuel in tank.</p> <p data-bbox="477 1184 1065 1241">a. Check fuel level in tank. If OK, do step 2.</p> <p data-bbox="477 1209 781 1236">b. Service fuel tank.</p> <p data-bbox="285 1272 1013 1299">Step 2. Fuel filter/water separator plugged with water.</p> <p data-bbox="477 1335 1179 1392">a. Drain fuel filter/water separator. Refer to PMCS in Section 5.</p>

Table 6-1. Operator Troubleshooting (continued)

MALFUNCTION	TEST OR INSPECTION	CORRECTIVE ACTION
4.	<u>ENGINE STARTS BUT WILL NOT KEEP RUNNING.</u>	
	Step 1.	Fuel waxing due to cold weather.
		a. Drain fuel filter/water separator. Refer to PMCS in Section 5. If OK, do step 2.
		b. Contact Organizational Maintenance to drain fuel tank and service with cold weather fuel grade.
	Step 2.	Fuel contaminated.
		a. Check fuel/filter water separator for contamination. Refer to PMCS in Section 5. If fuel OK, do step 3.
	Step 3.	Contact Organizational Maintenance.
5.	<u>ENGINE WILL NOT SHUT OFF.</u>	
	Step 1.	Fuel system malfunction.
		a. Set outriggers and shut down diesel engine. Shut off fuel supply shutoff valve at fuel tank. Refer to shutdown procedures, paragraph 5-3.3.
		b. Contact Organizational Maintenance.
6.	<u>ROUGH IDLE. WARM ENGINE.</u>	
	Step 1.	Intake air system restricted.
		a. Inspect air cleaner inlet hood. If OK, do step 2.
		b. Contact Organizational Maintenance to remove intake hood and air filter element. Replace air filter element and clean intake hood.
	Step 2.	Fuel contaminated.
		a. Check fuel filter/water separator for contamination. Refer to PMCS in Section 5. If fuel OK, do step 3.
	Step 3.	Contact Organizational Maintenance.

Table 6-1. Operator Troubleshooting (continued)

MALFUNCTION	TEST OR INSPECTION	CORRECTIVE ACTION
7.	<u>ENGRINE SURGES AT IDLE.</u>	
	Step 1.	Low fuel level in the fuel tank.
		a. Check fuel level in tank.
		b. Service fuel tank.
8.	<u>LOW LUBRICATING OIL PRESSURE.</u>	
	Step 1.	Incorrect oil level.
		a. Check engine oil level. If OK, do step 2.
		b. Add engine oil to correct level.
	Step 2.	Oil diluted with water.
		a. Inspect for missing oil fill cap, dipstick, etc. If OK, do step 3.
		b. Contact Organizational Maintenance to drain and refill engine oil.
	Step 3.	Oil leak due to loose or missing pipe plug.
		a. Check for external leak at rear of cylinder head, along fuel pump side of block, oil cooler cover and gear housing.
		b. Contact Organizational Maintenance.
9.	<u>LUBRICATING OIL PRESSURE TOO HIGH.</u>	
	Step 1.	Engine lubrication system malfunction.
		a. Contact Organizational Maintenance.

Table 6-1. Operator Troubleshooting (continued)

MALFUNCTION	TEST OR INSPECTION	CORRECTIVE ACTION
10. <u>LUBE OIL LOSS.</u>	Step 1.	External leaks. a. Visually inspect for oil leaks. If no leaks, do step 2. b. Contact Organizational Maintenance.
	Step 2.	Crankcase overfilled. a. Remove dipstick and check oil level. If OK, do step 3. b. Contact Organizational Maintenance to drain engine oil to proper level.
	Step 3.	Engine lubrication system malfunction. a. Contact Organizational Maintenance.
11. <u>CONTAMINATED ENGINE OIL.</u>	Step 1.	Engine lubrication system malfunction. a. Contact Organizational Maintenance.
12. <u>EXHAUST SMOKE EXCESSIVE UNDER LOAD.</u>	Step 1.	Engine overloaded. a. Downshift to lower gear.
	Step 2.	Fuel system malfunction. a. Contact Organizational Maintenance.
13. <u>ENGINE WILL NOT REACH RATED SPEED WHEN LOADED.</u>	Step 1.	Vehicle overloaded. a. Reduce load or downshift to lower gear.

Table 6-1. Operator Troubleshooting (continued)

MALFUNCTION	TEST OR INSPECTION	CORRECTIVE ACTION
	Step 2.	Fuel system malfunction. a. Contact Organizational Maintenance.
14.	<u>LOW POWER.</u>	
	Step 1.	Vehicle overloaded. a. Reduce load or downshift to lower gear.
	Step 2.	Engine oil level too high. a. Remove dipstick and check engine oil level. If OK, do step 3. b. Contact Organizational Maintenance to drain engine oil to proper level.
	Step 3.	Fuel system malfunction. a. Contact Organizational Maintenance.
15.	<u>ENGINE MISFIRING.</u>	
	Step 1.	Fuel system malfunction. a. Contact Organizational Maintenance.
16.	<u>FUEL KNOCK.</u>	
	Step 1.	Engine overloaded. a. Downshift to lower gear.
	Step 2.	Fuel system malfunction. a. Contact Organizational Maintenance.

Table 6-1. Operator Troubleshooting (continued)

MALFUNCTION	TEST OR INSPECTION	CORRECTIVE ACTION
17. <u>EXCESSIVE FUEL CONSUMPTION.</u>	Step 1.	Operator Technique. a. Review Section 5 - Operating Instructions. If OK, do step 2.
	Step 2.	Fuel leak. a. Inspect for fuel leaks. If OK, do step 3. b. Contact Organizational Maintenance to repair leaks.
	Step 3.	Fuel system malfunction. a. Contact Organizational Maintenance.
18. <u>EXCESSIVE VIBRATION.</u>	Step 1.	Engine drive component failure. a. Contact Organizational Maintenance.
19. <u>EXCESSIVE ENGINE NOISES.</u>	Step 1.	Drive belt squeal, insufficient tension or abnormally high loading. a. Check belt tension and condition of drive belt. Refer to PMCS in Section 5. b. Contact Organizational Maintenance to replace drive belt or tensioner.
	Step 2.	Defective engine. a. Contact Organizational Maintenance.

Table 6-1. Operator Troubleshooting (continued)

MALFUNCTION	TEST OR INSPECTION	CORRECTIVE ACTION
20.	<u>FUEL OR OIL LEAKING FROM EXHAUST MANIFOLD.</u>	<p>Step 1. Defective engine.</p> <p>a. Contact Organizational Maintenance.</p>
21.	<u>COOLANT TEMPERATURE ABOVE NORMAL.</u>	<p>Step 1. Low coolant level.</p> <p>a. Check coolant level. If OK, do step 2.</p> <p>b. Service coolant system.</p> <p>Step 2. Radiator fins damaged or obstructed with debris.</p> <p>a. Inspect radiator fins for damage and debris. If OK, do step 3.</p> <p>b. Clean debris from radiator.</p> <p>c. Contact Organizational Maintenance.</p> <p>Step 3. Collapsed radiator hose.</p> <p>a. Inspect upper and lower radiator hoses. If OK, do step 4.</p> <p>b. Contact Organizational Maintenance to replace radiator hose(s).</p> <p>Step 4. Engine oil level too high or too low.</p> <p>a. Remove dipstick and check engine oil level. If OK, do step 5.</p> <p>b. Add engine oil to proper level.</p> <p>c. Contact Organizational Maintenance to drain engine oil to proper level.</p>

Table 6-1. Operator Troubleshooting (continued)

MALFUNCTION	TEST OR INSPECTION	CORRECTIVE ACTION
	Step 5.	Loose fan drive belt. <ul style="list-style-type: none"> a. Inspect fan drive belt and belt tensioner. Refer to PMCS in Section 5. If OK, do step 6. b. Contact Organizational Maintenance to replace fan drive belt and/or tensioner.
	Step 6.	Engine overloaded. <ul style="list-style-type: none"> a. Reduce load and downshift to lower gear.
	Step 7.	Defective engine. <ul style="list-style-type: none"> a. Contact Organizational Maintenance.
22.	<u>COOLANT LOSS.</u>	
	Step 1.	Radiator leaking coolant. <ul style="list-style-type: none"> a. Visually inspect radiator hoses and connections to locate leak. If OK, do step 2. b. Contact Organizational Maintenance to replace radiator components.
	Step 2.	External engine leaks. <ul style="list-style-type: none"> a. Visually inspect engine and components for seal or gasket leaks. b. Contact Organizational Maintenance to repair leaks.
23.	<u>COOLANT TEMPERATURE BELOW NORMAL.</u>	
	Step 1.	Temperature sensor or gauge malfunction. <ul style="list-style-type: none"> a. Contact Organizational Maintenance.

Table 6-1. Operator Troubleshooting (continued)

MALFUNCTION	TEST OR INSPECTION	CORRECTIVE ACTION
24.	<u>CONTAMINATED COOLANT.</u>	<p>Step 1. Coolant system malfunction.</p> <p>a. Contact Organizational Maintenance to repair coolant system.</p>
25.	<u>ALTERNATOR NOT CHARGING OR INSUFFICIENT CHARGING.</u>	<p>Step 1. Loose or corroded battery connections.</p> <p>a. Inspect battery connection. If OK, do step 2.</p> <p>b. Contact Organizational Maintenance to clean or tighten battery connections.</p> <p>Step 2. Fan drive belt slipping.</p> <p>a. Inspect fan drive belt tensioner by hand. Refer to PMCS in Section 5. If OK, do step 3.</p> <p>b. Contact Organizational Maintenance to replace fan drive belt and/or tensioner.</p> <p>Step 3. Alternator pulley loose on shaft.</p> <p>a. Inspect alternator pulley. If OK, do step 4.</p> <p>b. Contact Organizational Maintenance to tighten alternator pulley.</p> <p>Step 4. Charging system malfunction.</p> <p>a. Contact Organizational Maintenance.</p>

Table 6-1. Operator Troubleshooting (continued)

MALFUNCTION	TEST OR INSPECTION	CORRECTIVE ACTION
26.	<u>CRANE WILL NOT MOVE OR MOVES ERRATICALLY (TRANSMISSION FAILURE).</u>	<p>Step 1. Low transmission oil level.</p> <p>a. Remove dipstick and check transmission oil level. If OK, do step 2. Refer to PMCS in Section 5.</p> <p>b. Fill to proper level.</p> <p>Step 2. Transmission shift lever at N-Neutral.</p> <p>a. Check position of transmission shift lever.</p> <p>Step 3. Defective transmission.</p> <p>a. Contact Organizational Maintenance.</p>
27.	<u>TRANSMISSION OIL TEMPERATURE ABOVE NORMAL.</u>	<p>Step 1. Low transmission oil level.</p> <p>a. Remove dipstick and check oil level. Refer to PMCS in Section 5. If OK, do step 2.</p> <p>b. Fill to proper level.</p> <p>Step 2. Defective transmission.</p> <p>a. Contact Organizational Maintenance.</p>
28.	<u>BRAKES ARE POOR OR DO NOT APPLY.</u>	<p>Step 1. Low master brake cylinder fluid level.</p> <p>a. Check brake fluid level in master cylinder. Refer to PMCS in Section 5. If OK, Contact Organizational Maintenance.</p> <p>b. Service master brake cylinder.</p>

Table 6-1. Operator Troubleshooting (continued)

MALFUNCTION	TEST OR INSPECTION	CORRECTIVE ACTION
29.	<u>HARD TO STEER LEFT AND RIGHT.</u>	<p data-bbox="285 443 678 468">Step 1. Hydraulic oil low.</p> <p data-bbox="477 506 1235 621">a. Check hydraulic oil level in reservoir. Refer to PMCS in Section 5. If OK, do step 2. b. Service hydraulic reservoir.</p> <p data-bbox="285 659 756 684">Step 2. Steering system failure.</p> <p data-bbox="477 722 1011 747">a. Contact Organizational Maintenance.</p>
30.	<u>SLOW OR ERRATIC OPERATION OF OUTRIGGER CYLINDERS.</u>	<p data-bbox="285 877 683 903">Step 1. Low hydraulic oil.</p> <p data-bbox="477 940 1252 1056">a. Check hydraulic oil level. Refer to PMCS in Section 5. If OK, do step 2. b. Service hydraulic reservoir.</p> <p data-bbox="285 1094 834 1119">Step 2. Outrigger system malfunction.</p> <p data-bbox="477 1157 1011 1182">a. Contact Organizational Maintenance.</p>
31.	<u>OUTRIGGER SYSTEM WILL NOT ACTIVATE.</u>	<p data-bbox="285 1312 678 1337">Step 1. Hydraulic oil low.</p> <p data-bbox="477 1375 1252 1491">a. Check hydraulic oil level. Refer to PMCS in Section 5. If OK, do step 2. b. Service hydraulic reservoir.</p> <p data-bbox="285 1528 834 1554">Step 2. Outrigger system malfunction.</p> <p data-bbox="477 1591 1011 1617">a. Contact Organizational Maintenance.</p>

Table 6-1. Operator Troubleshooting (continued)

MALFUNCTION	TEST OR INSPECTION	CORRECTIVE ACTION
32.	<u>OUTRIGGER SYSTEM ACTIVATES. BUT SELECTED OUTRIGGER WILL NOT RETRACT OR EXTEND AND LOWER AS DESIRED.</u>	<p>Step 1. Outrigger system malfunction.</p> <p>a. Contact Organizational Maintenance.</p>
33.	<u>BOOM RAISES OR LOWERS ERRATICALLY.</u>	<p>Step 1. Hydraulic oil low.</p> <p>a. Check hydraulic oil level. Refer to PMCS in Section 5. If OK, do step 2.</p> <p>b. Service hydraulic reservoir.</p> <p>Step 2. Low engine rpm.</p> <p>a. Increase engine rpm.</p> <p>Step 3. Hydraulic system failure.</p> <p>a. Contact Organizational Maintenance.</p>
34.	<u>BOOM RAISES OR LOWERS SLOWLY.</u>	<p>Step 1. Low hydraulic oil.</p> <p>a. Check hydraulic oil level. Refer to PMCS in Section 5. If OK, do step 2.</p> <p>b. Service hydraulic reservoir.</p> <p>Step 2. Low engine rpm.</p> <p>a. Increase engine rpm.</p> <p>Step 3. Cold hydraulic oil.</p> <p>a. Operate crane to bring oil to operating temperature.</p>

Table 6-1. Operator Troubleshooting (continued)

MALFUNCTION	TEST OR INSPECTION	CORRECTIVE ACTION
	Step 4.	Hydraulic system failure. a. Contact Organizational Maintenance.
35.	<u>BOOM WILL NOT RAISE OR LOWER.</u>	
	Step 1.	Low hydraulic oil. a. Check hydraulic oil level. Refer to PMCS in Section 5. If OK, do step 2. b. Service hydraulic reservoir.
	Step 2.	Excessive load. a. Reduce load as required.
	Step 3.	Hydraulic system failure. a. Contact Organizational Maintenance.
36.	<u>ERRATIC OPERATION OF TELESCOPE CYLINDER.</u>	
	Step 1.	Low hydraulic oil. a. Check hydraulic oil level. Refer to PMCS in Section 5. If OK, do step 2. b. Service hydraulic reservoir.
	Step 2.	Low engine rpm. a. Increase engine rpm.
	Step 3.	Lack of lubrication on boom section. a. Lubricate boom sections. Refer to paragraph 6-1.5.
	Step 4.	Side loading causing improper boom alignment. a. Reduce load. Use proper hoisting procedures.

Table 6-1. Operator Troubleshooting (continued)

MALFUNCTION	TEST OR INSPECTION	CORRECTIVE ACTION
	Step 5.	Hydraulic system failure. a. Contact Organizational Maintenance.
37.	<u>TELESCOPE CYLINDER WILL NOT EXTEND OR RETRACT.</u>	
	Step 1.	Low hydraulic oil level. a. Check hydraulic oil level. Refer to PMCS in Section 5. If OK, do step 2. b. Service hydraulic reservoir.
	Step 2.	Excessive load. a. Reduce load.
	Step 3.	Hydraulic system failure. a. Contact Organizational Maintenance.
38.	<u>HOIST WILL NOT RAISE LOAD.</u>	
	Step 1.	Load capacity exceeded. a. Reduce load.
	Step 2.	Low hydraulic oil. a. Check hydraulic oil level. Refer to PMCS in Section 5. If OK, do step 3. b. Service hydraulic reservoir.
	Step 3.	Hydraulic system failure. a. Contact Organizational Maintenance.

Table 6-1. Operator Troubleshooting (continued)

MALFUNCTION	TEST OR INSPECTION	CORRECTIVE ACTION
39.	<u>HOIST WILL NOT LOWER LOAD.</u>	
	Step 1.	Malfunctioning hoist brake.
		a. Contact Organizational Maintenance.
40.	<u>SLOW OR ERRATIC HOIST OPERATION.</u>	
	Step 1.	Low engine rpm.
		a. Increase rpm.
	Step 2.	Hydraulic system failure.
		a. Contact Organizational Maintenance.
41.	<u>BOOM SWING OPERATIONS ERRATIC IN EITHER DIRECTION.</u>	
	Step 1.	Low engine rpm.
		a. Increase rpm.
	Step 2.	Low hydraulic oil.
		a. Check hydraulic oil level. Refer to PMCS in Section 5. If OK, do step 3.
		b. Service hydraulic reservoir.
	Step 3.	Insufficient lubricant on swing bearing.
		a. Inspect swing bearing. Lubricate bearing. Refer to paragraph 6-1.5.
	Step 4.	Crane not level.
		a. Level crane using outriggers.
	Step 5.	Crane overloaded.
		a. Reduce load.

Table 6-1. Operator Troubleshooting (continued)

MALFUNCTION	TEST OR INSPECTION	CORRECTIVE ACTION
	Step 6.	Swing system failure. a. Contact Organizational Maintenance.
42.	<u>SWING BRAKE SYSTEM WILL NOT OPERATE.</u>	
	Step 1.	Low hydraulic oil. a. Check hydraulic oil level. Refer to PMCS in Section 5. If OK, do step 2. b. Service hydraulic reservoir.
	Step 2.	Swing system failure. a. Contact Organizational Maintenance.

6-3. INSTALLING CABLE ON THE HOIST.**WARNING**

Wear heavy gloves and safety glasses when working with the hoist cable. Failure to follow this warning could result in personal injury.

CAUTION

If cable is wound from the storage reel onto the drum, the reel should be rotated in the same direction as the hoist.

NOTE

The cable should preferably be straightened before installation on the hoist drum.

Install cable on the hoist drum using Figure 6-3 and the following procedures.

- a. Position the cable over the boom nose sheave and route to the hoist drum.

- b. Position the hoist drum with the cable anchor slot on top, (Figure 6-3).
- c. Insert the cable through the slot and position around the anchor wedge.

NOTE

The end of the cable should be even with the bottom of the anchor wedge.

- d. Position the anchor wedge in the drum slot; pull firmly on the free end of the cable to secure the wedge.

NOTE

If the wedge does not seat securely in the slot, carefully tap the top of the wedge with a mallet.

- e. Slowly rotate the drum, ensuring the first layer of cable is evenly wound onto the drum.
- f. Install the remainder of the cable, as applicable.

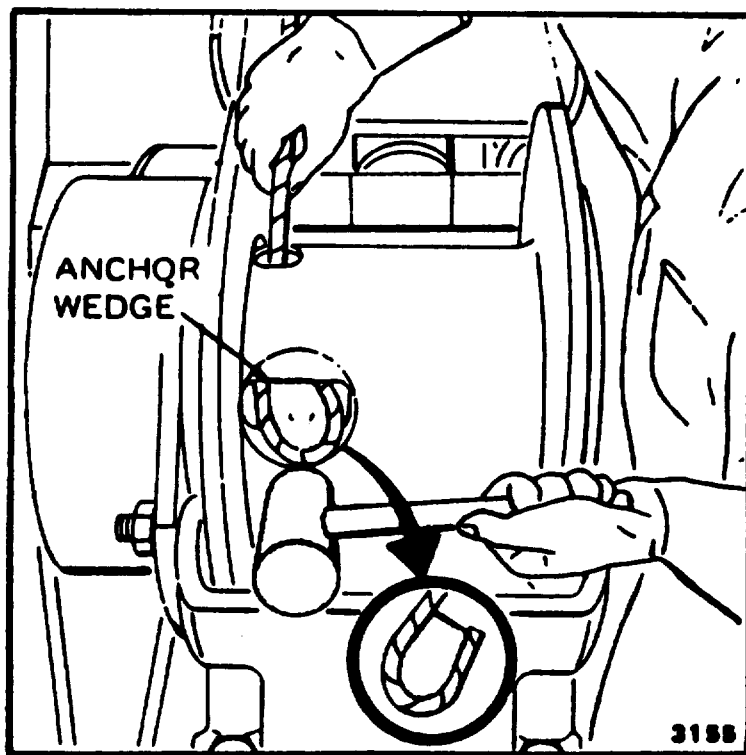

Figure 6-3. Installing Cable Anchor Wedge

6-4. CABLE REEVING.

Within the limits of the load and range charts and permissible line pull, multi-part lines allow the operator to raise a greater load than can be raised with a single part line. This reeving should be accomplished by a qualified rigger using standard rigging procedures.

Figure 6-4 illustrates cable reeving for the AP308T which includes routing the cable over the upper boom nose sheave (1), lower boom nose sheave (2), hook block sheave (3), and lower boom nose sheave (4) with the cable terminating at the wedge socket (5).

LEGEND

- 1. Upper Boom Nose Sheave
- 2. Lower Boom Nose Sheave No. 1
- 3. Hook Block Sheave
- 4. Lower Boom Nose Sheave No. 2
- 5. Wedge Socket

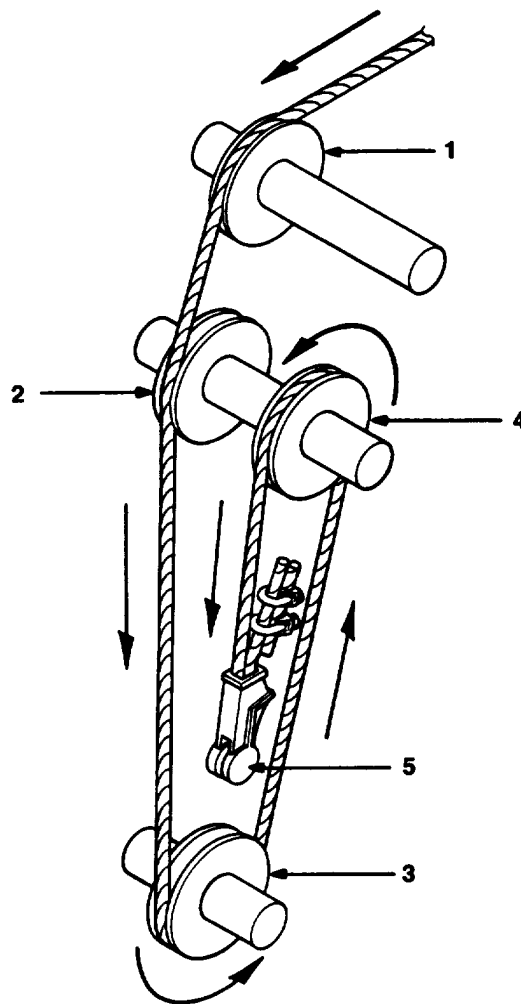

Figure 6-4. Boom Nose and Hook Block Cable Reeving

6-5. INSTALLING WEDGE AND SOCKET.

WARNING

Use only a wedge and socket of the correct size for the wire rope (cable) fitted. Failure to do so may result in the rope pulling through the fitting.

Make sure the live-loaded side of the cable is in line with the ears of the socket as shown in Figure 6-5. If the wire rope is loaded incorrectly, it will bend under a load as it leaves the socket. The edge of the socket will eventually wear into the rope causing damage and failure.

- a. Inspect the wedge and socket. Remove rough edges and burrs.
- b. If the wire rope is welded, cut the welded end off. This will allow distortion in the rope strands to adjust themselves at the end of the line.
- c. Insert wire rope into socket as shown in Figure 6-5 pulling the end through until it extends from the socket a distance of approximately nine times the rope diameter [a minimum of six inches (15.2 cm)].
- d. Place wedge in socket.
- e. Place a wire rope clip around the dead end by clamping a short piece of extra wire rope to the dead end. **DO NOT CLAMP THE LIVE END.** The u-bolt should bear against the dead end with the saddle of the clip resting against the short extra piece. Torque the u-bolts as follows:

Clip Size (Inches)	Torque (lb-ft, dry)	Clip Size (Inches)	Torque (lb-ft, dry)
1/8	3	5/8	75
3/16	4.5	3/4	75
1/4	15	7/8	130
5/16	15	1	130
3/8	30	1-1/8	200
7/16	40	1-1/4	200
1/2	45	1-3/8	360
9/16	50	1-1/2	360

- f. Secure ears of socket to a sturdy support. Pull wedge and rope into position with tension on the live side of the wire rope sufficiently tight enough to hold them in place.
- g. After final pin connections are made, increase loads gradually until wedge is properly seated.

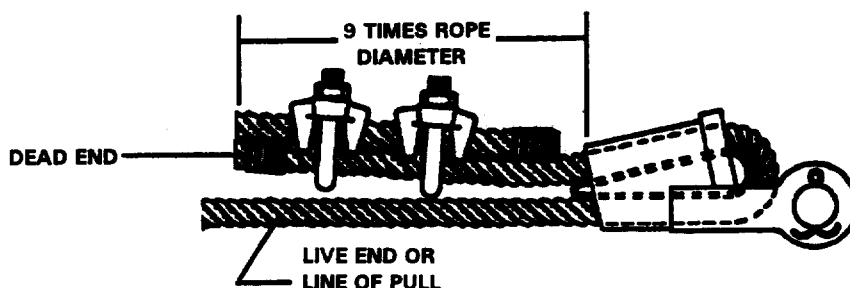

Figure -65. Dead-End Rigging/Wedge Socket

APPENDIX A**REFERENCES****A-1 SCOPE**

This appendix lists all forms and publications that are referenced in this manual.

A-2 PAMPHLETS

DA Pam 25-30 Consolidated Index of Army Publications and Blank Forms

DA Pam 738-750 The Army Maintenance Management System (TAMMS)

A-3 FORMS

DA Form 2404 Equipment Inspection and Maintenance Worksheet

DA Form 2028 Recommended Changes to Publications and Blank Forms

DA Form 2028-2 Recommended Changes to Equipment Technical Publications

SF 361 Transportation Discrepancy Report

SF 364 Report of Discrepancy (ROD)

SF 368 Product Quality Deficiency Report

A-4 SUPPLY BULLETINS**A-5 TECHNICAL BULLETINS****A-6 TECHNICAL MANUALS**

TM 43-0139 Painting Instructions for Field Use

A-7 FIELD MANUALS

FM 21-11 First Aid for Soldiers

A-8 MISCELLANEOUS PUBLICATIONS

CTA 50-970 Expendable Items (Except: Medical, Class V, Repair Parts and Heraldic Items)

APPENDIX B**COMPONENTS OF END ITEM AND BASIC ISSUE ITEMS LISTS****Section I. INTRODUCTION****B-1. SCOPE**

This appendix lists components of end item and basic issue items for the 10K Warehouse Crane, M469 to help you inventory items required for safe and efficient operation.

B-2. GENERAL

The components of end item and basic issue items lists are divided into the following sections.

a. Section II. Components of End Item

This listing is for informational purposes only, and is not authority to requisition replacements. These items are part of the end item, but are removed and separately packaged for transportation and shipment. As part of the end item, these items must be with the end item whenever it is issued or transferred between property accounts. Illustrations are furnished to assist you in identifying the items.

b. Section III. Basic Issue Items

These are the minimum essential items required to place the 1 OK Warehouse Crane in operation, to operate it, and perform emergency repairs. Although shipped separately, packaged BII must be with the crane during operation and whenever it is transferred between property accounts. The illustrations will assist you with hard to identify items. This manual is your authority to request/requisition replacement BII, based on TOE/MTOE authorization of the end item.

B-3. EXPLANATION OF COLUMNS

The following provides an explanation of columns found in the tabular listings.

a. Column (1) Illustration Number (Illus No.)

This column indicates the number of the illustration in which the item is shown.

b. Column (2) National Stock Number

Indicates the national stock number assigned to the item and will be used for requisitioning purposes.

B-3. EXPLANATION OF COLUMNS - Continued**c. Column (3) - Description (Description (CAGEC) and Part Number)**

Indicates the national item name and, if required, a minimum description to identify and locate the item. The last line for each item indicates the Commercial and Government Entity (CAGE) Code (in parentheses) followed by the part number.

d. Column (4) Unit of Measure (U/M)

Indicates the measure used in performing the actual operational/maintenance function. This measure is expressed by a two-character alphabetical abbreviation (e.g., EA, IN, PR).

e. Column (5) Quantity Required (Qty Reqd)

Indicates the quantity of the item authorized to be used with/on the equipment.

Section II. COMPONENTS OF END ITEM - 10K Warehouse Crane, M 469

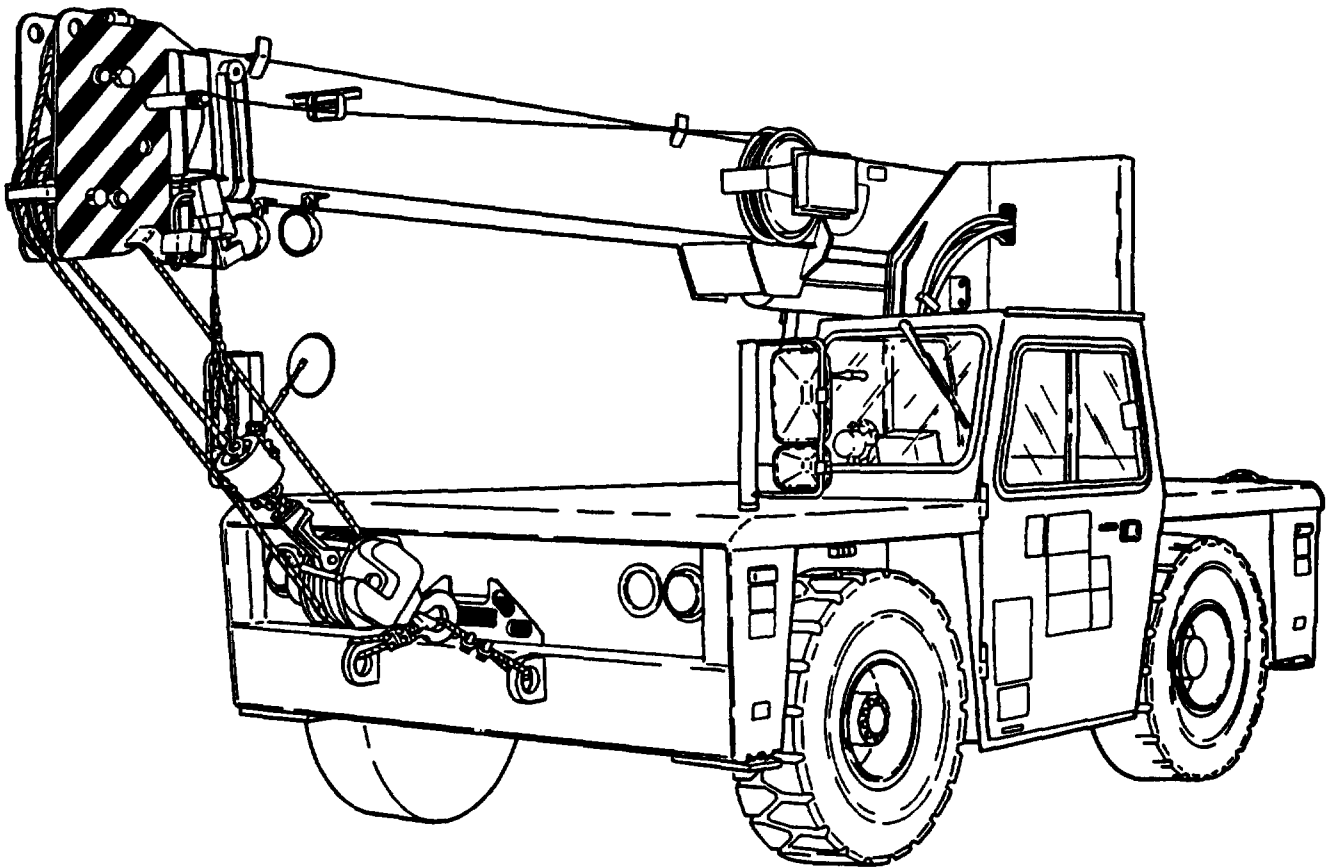

(1) Illus. No.	(2) National Stock Number	(3) Description (CAGEC) and Part Number	(4) Usable On Code	(5) Qty Reqd
1	3950-01-412-5345	Warehouse Crane, 10K DED, M 469 (12361) SK 950336	RWV	EA 1

Section III. BASIC ISSUE ITEMS

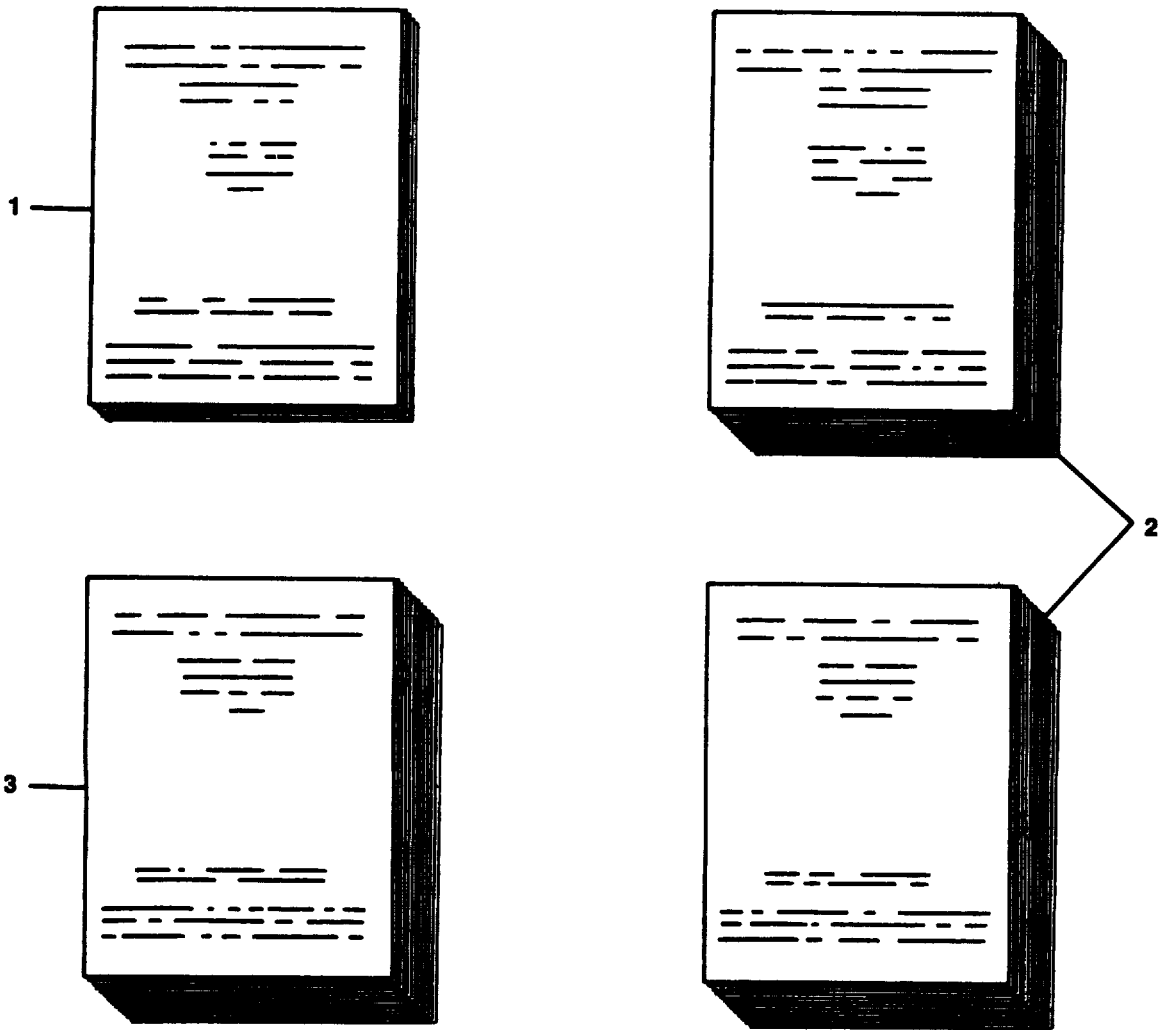

(1) Illus. No.	(2) National Stock Number	(3) Description (CAGEC) and Part Number	(4) Usable On Code U/M	(5) Qty Reqd
1		Operators Manual, TM 10-3950-672-10	EA	1
2		Organizational, Direct and General Support Maintenance Manual, TM 10-3950-672-24-1 and -2	EA	1
3		Repair Parts and Special Tools List (RPSTL) TM 10-3950-672-24P	EA	1

APPENDIX C**ADDITIONAL AUTHORIZATION LIST****Section I. INTRODUCTION****C-1. SCOPE**

This appendix lists additional items you are authorized for the support of the 10K Warehouse Crane, M469.

C-2. GENERAL

The list identifies items that do not have to accompany the crane and that do not have to be turned in with it. These items are all authorized to you by CTA, MTOE, TDA, or JTA.

C-3. EXPLANATION OF LISTING

The following provides an explanation of columns found in the tabular listings.

a. Column (1) National Stock Number

Indicates the national stock number assigned to the item and will be used for requisitioning purposes.

b. Column (2) Description (Description (CAGE) and Part Number)

Indicates the national item name and, if required, a minimum description to identify and locate the item. The last line for each item indicates the Commercial and Government Entity (CAGE) Code (in parentheses) followed by the part number.

c. Column (3) Unit of Measure (U/M)

Indicates the measure used in performing the actual operational/maintenance function. This measure is expressed by a two-character alphabetical abbreviation (e.g., EA, IN, PR).

d. Column (4) Quantity Required (Qty Reqd)

Indicates the quantity of the item authorized to be used with/on the equipment.

Section II. ADDITIONAL AUTHORIZATION LIST - 10K Warehouse Crane, M 469

(1) National Stock Number	(2) Description (CAGEC) and Part Number Usable On Code	(3) U/M	(4) Qty Reqd
<u>MTOE AUTHORIZED ITEMS</u>			
7520-00-559-9618	Bag, Pamphlet	RWV	EA 1
4240-00-052-3776	Goggles, Eye Protection	RWV	PR 2
8415-00-889-3767	Helmet, Construction	RWV	EA 2
6545-00-912-1200	Kit, First Aid	RWV	EA 1
<u>CTA AUTHORIZED ITEMS</u>			
NONE			

APPENDIX E
LOAD CHART

E-1. SCOPE

This appendix contains the load chart for the 10 K Warehouse Crane~~400~~.



**LOADCHARTS
AP308**

**75% STABILITY
ON OUTRIGGERS
& ON RUBBER**

**82035
SERIAL NUMBER**

Figure E-1. Load Chart, 10K Warehouse Crane (Sheet 1 of 9).

NOTES FOR LIFTING CAPACITIES

GENERAL:

1. Rated loads as shown on lift chart pertain to this machine as originally manufactured and equipped. Modifications to the machine or use of optional equipment other than that specified can result in a reduction of capacity.
2. Construction equipment can be hazardous if improperly operated or maintained. Operation and maintenance of this machine shall be in compliance with the information in the Operator's and Safety Handbook, Service Manual and Parts Manual supplied with this machine. If these manuals are missing, order replacements from the manufacturer through the distributor.
3. The operator and other personnel associated with machine shall fully acquaint themselves with the latest American National Standards Institute (ANSI) Safety Standards for cranes.

SETUP:

1. The machine shall be leveled on a firm supporting surface. Depending on the nature of the supporting surface, it may be necessary to have structural supports under the outrigger floats or tires to spread the load to a larger bearing surface.
2. For outrigger operation, outriggers shall be fully extended with tires raised free of crane weight before operating the boom or lifting loads.
3. If machine is equipped with front jack cylinder, the front jack cylinder shall be set in accordance with written procedure.
4. When equipped with extendable counterweight, the counterweight shall be fully extended before operation.
5. Tires shall be inflated to the recommended pressure before lifting on rubber.
6. With certain boom and hoist tackle combinations, maximum capacities may not be obtainable with standard cable lengths.
7. Do not travel with crane boom extension or jib erected.

OPERATION:

1. Rated loads at rated radius shall not be exceeded. Do not tip the machine to determine allowable loads. For clamshell or concrete bucket operation, weight of bucket and load must not exceed 80% of rated lifting capacities.
2. All rated loads have been tested to and meet minimum requirements of SAE J1063 OCT80 - Cantilevered Boom Crane Structures - Method of Test, and do not exceed 75% of the tipping load on outriggers as determined by SAE J765 OCT80 Crane Stability Test Code.
3. Rated loads include the weight of hookblock, slings and auxiliary lifting devices and their weights shall be subtracted from the listed rating to obtain the net load to be lifted. When more than the minimum required hoist reeving is used, the additional rope weight shall be considered part of the load to be handled.
4. Load ratings are based on freely suspended loads. No attempt shall be made to move a load horizontally on the ground in any direction.
5. Rated loads do not account for wind on lifted load or boom. It is recommended when wind velocity is above 20 m.p.h. (32km/h), rated loads and boom lengths shall be appropriately reduced.
6. Rated loads are for lift crane service only.
7. Do not operate at a radius or boom length where capacities are not listed. At these positions, the machine may overturn without any load on the hook.
8. The maximum load which can be telescoped is not definable because of variations in loadings and crane maintenance, but it is safe to attempt retraction and extension within the limits of the capacity chart.
9. When either boom length or radius or both are between values listed, the smallest load shown at either the next larger radius or next longer or shorter boom length shall be used.
10. For safe operation, the user shall make due allowances for his particular job conditions, such as: soft or uneven ground, out of level conditions, high winds, side loads, pendulum action, jerking or sudden stopping of loads, hazardous conditions, experience of personnel, two machine lifts, traveling with loads, electric wires, etc. Side pull on boom or jib is extremely dangerous.
11. If machine is equipped with individually controlled powered boom sections, the boom sections must be extended equally at all times.
12. Never handle personnel with this machine without written approval from Grove North America.
13. Keep load handling devices a minimum of 18 inches (45.7 cm) below boom head at all times.
14. The boom angle before loading should be greater than the loaded boom angle to account for deflection.
15. Capacities appearing above the bold line are based on structural strength and tipping should not be relied upon as a capacity limitation.

DEFINITIONS:

1. Operating Radius: Horizontal distance from a projection of the axis of rotation to the supporting surface before loading to the center of the vertical hoist line or tackle with load applied.
2. Loaded Boom Angle (Shown in Parenthesis on Main Boom Capacity Chart): is the angle between the boom base section and the horizontal, after lifting the rated load at the rated radius with the rated boom length.
3. Working Area: Areas measured in a circular arc about the center line of rotation as shown on the working area diagram.
4. Freely Suspended Load: Load hanging free with no direct external force applied except by the lift cable.
5. Side Load: Horizontal force applied to the lifted load either on the ground or in the air.

Figure E-1. Load Chart, 10K Warehouse Crane (Sheet 2 of 9).

**RATED LIFTING CAPACITIES IN POUNDS
ON OUTRIGGERS - 360°**

14-24 ft. BOOM

Radius in Feet	#01	
	Over Front	360°
5	17,000	17,000
6	15,000	15,000
8	13,000	13,000
10	11,000	11,000
12	9,500	8,840
14	8,100	6,200
16	6,900	4,910
18	5,660	4,040
20	4,700	3,400
22	3,990	2,920

A6-829-008085

1. Capacities do not exceed 75% of tipping loads as determined by test in accordance with SAE J765 OCT80.
2. Capacities appearing above the bold line are based on structural strength and tipping should not be relied upon as a capacity limitation.

**NO LOAD STABILITY FOR
ON OUTRIGGERS AND RUBBER CAPACITIES**

No Load Stability Data		Main Boom 24 ft.
Front (No load)	Min. boom angle (deg.) for indicated length	0
	Max. boom length (ft.) at 0 deg. boom angle	24
360 Deg. (No load)	Min. boom angle (deg.) for indicated length	0
	Max. boom length (ft.) at 0 deg. boom angle	24

ON RUBBER CAPACITIES

Radius in Feet	#05		#06
	Stationary Capacity Defined Arc (3) Over Front	Stationary Capacity 360 Degree Arc	Pick & Carry Cap. Up to 2.5 MPH Boom Centered (6) Over Front
4	17,000	11,450	15,000
5	17,000	10,050	15,000
6	15,000	8,920	13,700
7	14,000	7,790	12,050
8	13,000	6,200	10,700
10	8,190	4,300	8,190
12	5,610	3,200	5,610
14	4,360	2,650	4,360
16	3,480	2,160	3,480
18	2,870	1,770	2,870
20	2,410	1,460	2,410
22	2,060	1,230	2,060

A6-829-008407B

#LMI operating code. Refer to LMI manual for instructions.

1. Capacities are in pounds and do not exceed 75% of tipping loads as determined by test in accordance with SAE J765 OCT80.
2. Capacities are applicable to machines equipped with 10.00 x 15 (16 ply) mining & industrial tires, at 120 psi cold inflation pressure.
3. Defined Arc - Over front includes 6° on either side of longitudinal centerline of machine.
4. Capacities are applicable only with machine on firm level surface.
5. All rubber lifting depends on proper tire inflation, capacity and condition. Capacities must be reduced for lower tire inflation pressures. Damaged tires are hazardous to safe operation of crane.
6. For pick and carry operation, the boom, using the shortest practical boom length, must be centered over front of machine. When handling loads in the structural range with capacities close to maximum ratings, travel should be reduced to creep speed*. 2.5 mph capacities are permissible on main boom only, NOT on boom extension.

*Creep - not over 200 ft. of movement in any 30 minute period and not to exceed 1 mph.

Figure E-1. Load Chart, 10K Warehouse Crane (Sheet 3 of 9).

10 FT. - 15 FT. TELE BOOM EXTENSION ON OUTRIGGERS - 360° AND OVER FRONT
14 FT. - 24 FT. BOOM

Radius in Feet	360 Degrees				Over Front			
	*10 ft. Tele. Ext.		15 ft. Tele. Ext.		*10 ft. Tele. Ext.		15 ft. Tele. Ext.	
	#21	#24	#31	#34	#21	#24	#31	#34
	0°	45°	0°	45°	0°	45°	0°	45°
8	7,000				7,000			
10	6,500		4,150		6,500		4,150	
12	6,000		3,800		6,000		3,800	
14	5,500	4,500	3,400		5,500	4,500	3,400	
16	5,000	4,200	3,150		5,000	4,200	3,150	
18	4,210	3,900	2,950	2,600	4,500	3,900	2,950	2,600
20	3,500	3,500	2,800	2,550	4,200	3,600	2,800	2,550
22	2,960	2,960	2,650	2,500	3,700	3,350	2,650	2,500
24	2,540	2,540	2,550	2,450	3,390	3,150	2,550	2,450
26	2,200	2,200	2,340	2,340	2,970	2,970	2,500	2,400
28	1,920		2,070	2,070	2,640		2,450	2,250
30	1,680		1,840	1,840	2,360		2,350	2,100
32	1,480		1,650		2,130		2,200	
34			1,480				2,000	
36			1,340				1,780	
38			1,210				1,600	

A6-829-013679

#LMI operating code. Refer to LMI manual for operating instructions.

*10 ft. capacities applicable to both the 10 ft. fixed and 10 ft. tele. boom extension.

BOOM EXTENSION CAPACITY NOTES:

1. All capacities above the bold line are based on structural strength of boom extension and do not exceed 75% of tipping loads on outriggers in accordance with SAE J765 OCT80.
2. 10 ft. and 15 ft. boom extension lengths may be used for double or single line lifting service.
3. Rated load is based on radius, regardless of main boom length.
4. **WARNING:** Operation of this machine with heavier loads than the capacities listed is strictly prohibited. Machine tipping with boom extension occurs rapidly and without advance warning.
5. For all boom extension lifting service, links must be in place and upper rear pin in boom extension mounting bracket must be removed.
6. Capacities listed are with fully extended outriggers only.
7. No load stability on outriggers 360° with 10-15 ft. tele. extension installed:
 - a. Minimum boom angle for 24 ft. main boom = 0°
 - b. Maximum main boom length at 0° main boom angle = 24 ft.
8. When lifting loads, the minimum allowable boom angle is 3° with 0° offset and 48° with 45° offset.

Figure E-1. Load Chart, 10K Warehouse Crane (Sheet 4 of 9).

10 FT. - 15 FT. TELE BOOM EXTENSION ON RUBBER - 360° AND DEFINED ARC OVER FRONT
14 FT. - 24 FT. BOOM

Radius in Feet	360 Degrees				**Defined Arc (3) Over Front			
	*10 ft. Tele. Ext.		15 ft. Tele. Ext.		*10 ft. Tele. Ext.		15 ft. Tele. Ext.	
	#25	#28	#35	#38	#25	#28	#35	#38
	0°	45°	0°	45°	0°	45°	0°	45°
8	6,760				7,000			
10	4,610		4,150		6,500		4,150	
12	3,420		3,370		5,660		3,800	
14	2,660	2,660	2,650		4,310	4,310	3,400	
16	2,110	2,110	2,140		3,430	3,430	3,150	
18	1,690	1,690	1,770	1,770	2,810	2,810	2,950	2,600
20	1,360	1,360	1,480	1,480	2,350	2,350	2,510	2,510
22	1,100	1,100	1,250	1,250	1,990	1,990	2,130	2,130
24	880	880	1,060	1,060	1,710	1,710	1,830	1,830
26	710	710	910	910	1,480	1,480	1,590	1,590
28	560		780	780	1,290		1,380	1,380
30	430		670	670	1,120		1,210	1,210
32			570		990		1,070	
34			490				940	
36			410				830	
38			350				730	

A6-829-010772

A6-829-010773

#LMI operating code. Refer to LMI manual for operating instructions.

*10 ft. capacities applicable to both the 10 ft. fixed and 10 ft. tele. boom extension.

BOOM EXTENSION CAPACITY NOTES:

- All capacities above the bold line are based on structural strength of boom extension and do not exceed 75% of tipping loads on rubber in accordance with SAE J765 OCT80.
- 10 ft. and 15 ft. boom extension lengths may be used for double or single line lifting service.
- Rated load is based on radius, regardless of main boom length.
- WARNING:** Operation of this machine with heavier loads than the capacities listed is strictly prohibited. Machine tipping with boom extension occurs rapidly and without advance warning.
- For all boom extension lifting service, links must be in place and upper rear pin in boom extension mounting bracket must be removed.
- No load stability on rubber 360° with 10-15 ft. tele. extension installed:
 - Minimum boom angle for 24 ft. main boom = 0°
 - Maximum main boom length at 0° main boom angle = 24 ft.
- When lifting loads, the minimum allowable boom angle is 3° with 0° offset and 48° with 45° offset.

Figure E-1. Load Chart, 10K Warehouse Crane (Sheet 5 of 9).

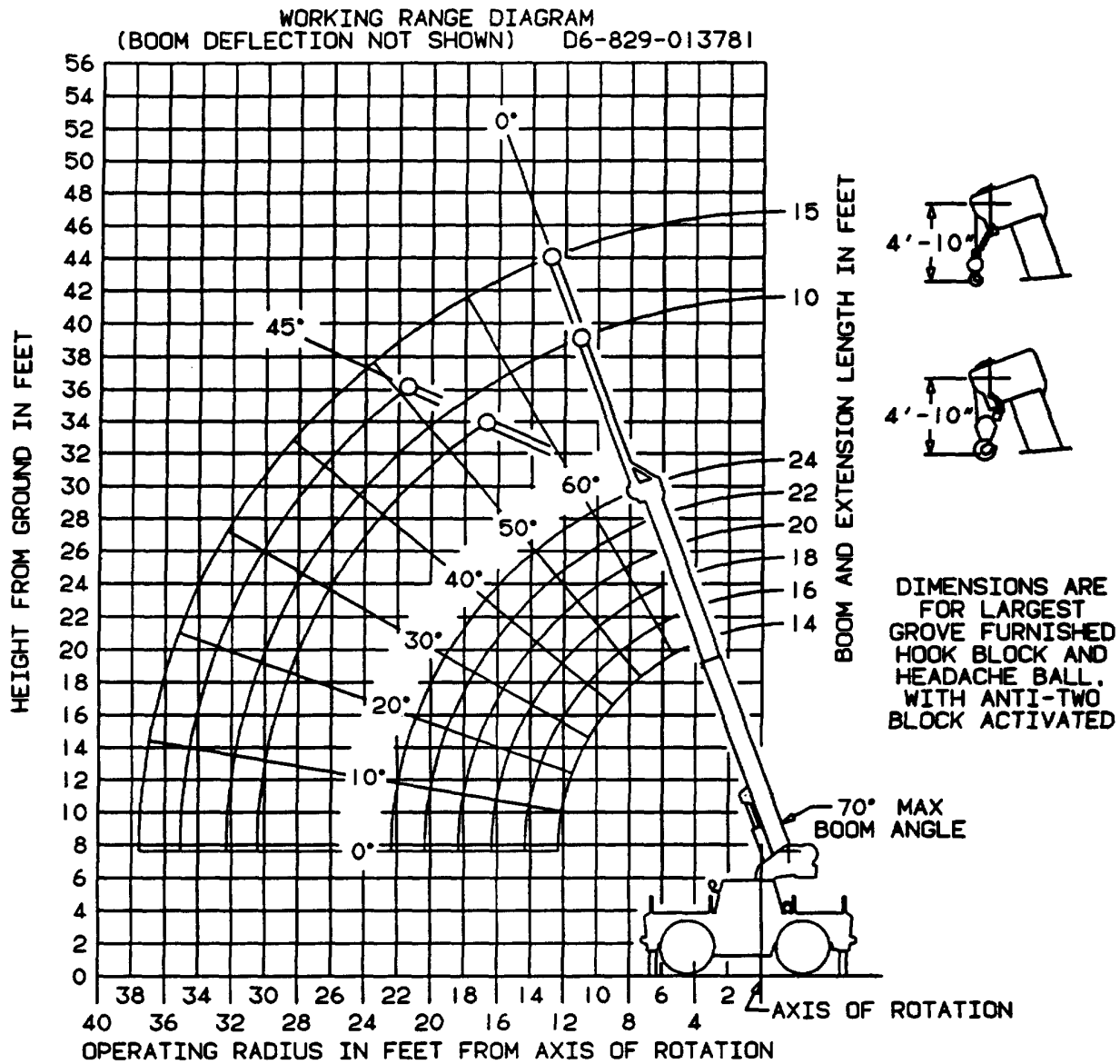
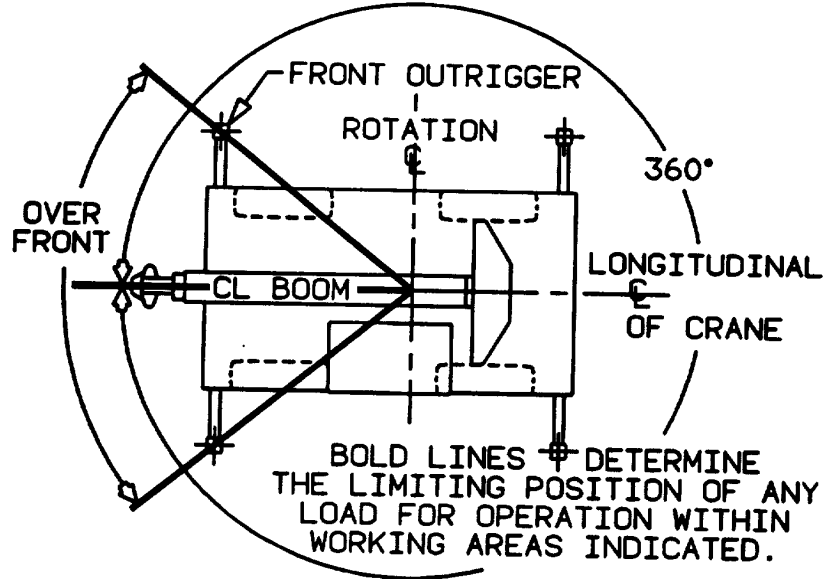

Figure E-1. Load Chart, 10K Warehouse Crane (Sheet 6 of 9).

6-829-007918



LIFTING ON OUTRIGGERS

6-829-007917

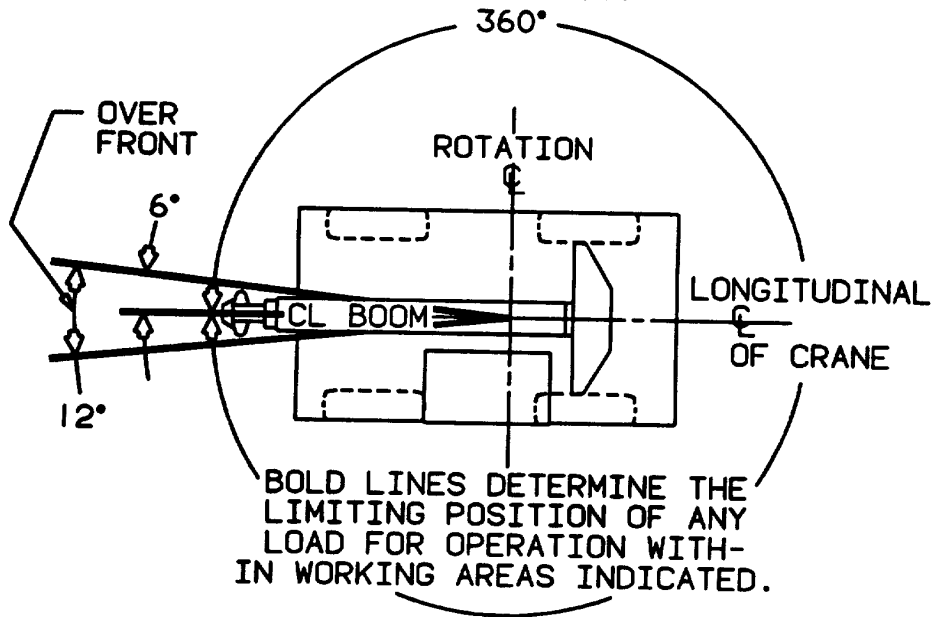

LIFTING ON RUBBER

Figure E-1. Load Chart, 10K Warehouse Crane (Sheet 7 of 9).

LOAD DISTRIBUTION CHART FOR CARRY DECK

6-829-007988/6-829-008043

MAXIMUM ALLOWABLE LOAD

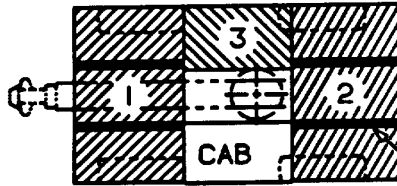

AREA 1	26.5SQ.FT/2.46SQ.M	6,625LBS/3000KGS
AREA 2	25.9SQ.FT/2.40SQ.M	6,475LBS/2930KGS
AREA 3	8.5SQ.FT/0.79SQ.M	2,125LBS/ 960KGS
TOTAL		60.9SQ.FT/5.65SQ.M 15,225LBS/6890KGS

(FRAME RAIL AREA. TYP)

1. MAXIMUM TRAVEL SPEED WITH ANY OR ALL LOADS---2.5 MPH./4 KPH.
2. LOADS TO BE TRANSPORTED ON SMOOTH LEVEL FIRM SURFACES ONLY.
3. BOOM MUST BE RETRACTED AND IN CENTER FORWARD POSITION.
4. ANY COMBINATION OR TOTAL OF AREAS 1,2,& 3 MAY BE USED.
5. LIFTING IS NOT PERMITTED WHEN CARRY DECK IS LOADED EXCEPT FOR LOADING AND UNLOADING CARRY DECK.
6. RATED PICK AND CARRY LOADS MAY BE TRANSPORTED ON DECK AREAS 1 AND 2 PROVIDED THE LOAD IS CRIBBED DIRECTLY ON THE FRAME RAILS.

LINE PULLS AND REEVING INFORMATION

HOISTS	CABLE SPECS.	PERMISSIBLE LINE PULLS
Main Model HO-12	9/16" (14 mm) 18x19 Class or 35x7 Rotation Resistant Min. Breaking Str. 37,000 lbs.	7,400 lbs.
Main Model HO-12	9/16" (14 mm) 6x37 Class EIPS, IWRC Special Flexible Min. Breaking Str. 33,600 lbs.	7,400 lbs.
Main Model HO-12	12 mm 40x7 Class Rotation Resistant Min. Breaking Str. 28,460 lbs.	5,692 lbs.

SEARCHER HOOK INFORMATION

The LMI controlling code for Searcher Hook usage is #07 for main boom on outriggers and #08 for main boom on rubber. Searcher Hook Maximum Capacity is 3,000 lbs. on outriggers. Do not exceed Searcher Hook capacity or given stability capacities on rubber. The use of the searcher hook is to be limited to freely suspended vertical lifts only. The main boom angle is not to exceed 25° from horizontal.

Figure E-1. Load Chart, 10K Warehouse Crane (Sheet 8 of 9).

TIRE INFLATION - PSI (BAR)					
SIZE (FRONT & REAR)	LOAD RANGE	TRA CODE	LIFTING SERVICE		TRAVEL
			CREEP & STATIC	2.5 MPH (4.0 KPH)	
10.00 x 15 AND 36 X 11 - 15	H(16)	—	120 (8.3)	115 (7.9)	115 (7.9)

Figure E-1. Load Chart, 10K Warehouse Crane (Sheet 9 of 9).

ALPHABETICAL INDEX

A

	Page
Accessory Controls and Indicators	5-2
Additional Authorization List	C-1
Air Cleaner, Check Condition of Indicator	5-15
Alternator Charging Indicator	5-6
Antifreeze & Coolant, Check for Proper Level	5-13
Antitwo-block System	4-4
Antitwo-block System, Check for Proper Operation	5-20
Axles	4-2

B

Backup Alarm	5-8
Basic Issue Items	B-1
Battery	5-20
Battery, Operator Inspection	5-21
Boom Angle Indicator, Check for Proper Operation	5-12
Boom, Inspection	5-22
Boom Light Switch	5-6
Boom Assembly	4-3
Boom Sheaves & Hook Block, Inspection	5-16
Brake Master Cylinder, Fluid Level Check	5-21
Brake System	4-2
Brakes, Service & Parking	5-19

C

Cab Assembly	4-1
Cab Door Latch and Lock	5-6
Cab Circulating Fan	5-6
Cab Heater, Operating	5-35
Cable Reeving	6-30
Carrier Frame Assembly	4-1
Checking Unpacked Equipment	3-1
Cold Weather Operation	2-23
Cold Weather Starting	5-24
Cold Start Switch	5-2
Components of End Item	B-1
Controlled Free-fall Hoist	2-17
Control Levers & Linkage, Check for Proper Operation	5-20
Control Panel Gauges, Check for Proper Operation	5-19
Controls and Indicators	5-1
Converter Oil Temperature Gauge	5-1
Coolant & Antifreeze, Check for Proper Level	5-13

ALPHABETICAL INDEX (continued)

C (continued)

	Page
Counterweight, Inspection	5-21
Crane Controls and Indicators	5-6
Crane Travel Operation	5-25
Craning Operation	2-8

D

Deprocessing Unpacked Equipment	3-1
Dome Light	5-5
Don't Forget	2-24
Drive Train	4-2
Driving the Crane	5-26

E

Electrical Hazards	2-18
Electrical System	4-4
Elevating the Boom	5-31
Emergency Load Lowering Procedures	5-34
Engine	4-1
Engine Controls and Indicators	5-1
Engine Coolant, Check for Proper Operation	5-13
Engine Coolant Temperature Gauge	5-1
Engine Crankcase, Oil Level Check	5-14
Engine Oil Pressure Gauge	5-1
Exhaust System, Inspection	5-22
Expendable/Durable Supplies and Materials List	D-1
Extending the Boom	5-32

F

Fan Belts, Inspection	5-22
Fire Extinguisher	5-6
Fire Extinguisher, Check Charge Indicator	5-12
Foot Brake Pedal	5-6
Foot Throttle Pedal	5-2
Fuel Filter/Water Separator, Draining	5-18
Fuel Quantity Gauge	5-1
Fuel Tank	4-1
Fuel Tank and Lines, Inspection	5-18
Fuels, Recommended	5-11
Functional Check	5-27

ALPHABETICAL INDEX (continued)

G

Page

General Crane Operation5-27

H

Heater/Defroster4-4
 Heater/Defroster Air Temperature Control5-6
 Heater/Defroster Fan Switch5-6
 Hoist4-3
 Hoist Control Lever5-7
 Hoist Drum & Motor, Check for Proper Operation5-17
 Hook Block & Boom Sheaves, Inspection5-16
 Horn Button Switch5-2
 Hourmeter5-2
 Hydraulic Cylinders & Valves, Inspection5-22
 Hydraulic Lines, Hoses, and Fittings, Inspection5-21
 Hydraulic Oil Cooler, Check for Leaks5-16
 Hydraulic Oil Recommendations6-3
 Hydraulic Reservoir, Fluid Level Check5-15
 Hydraulic Systems and Components4-2

I, J, K

Ignition Switch5-1
 Installing Cable on the Hoist6-29
 Installing Wedge and Socket6-31
 Introduction1-1

L

Level Indicator5-6
 Lift Control Lever5-7
 Lights/Horn, Check for Broken Lenses5-12
 Lights Switch5-5
 List of Specifications1-1
 Load ChartE-1
 Low Oil Pressure/High Engine Temperature Indicator5-2
 Lowering the Boom5-32
 Lowering Hoist Cable5-33
 Lubrication Instructions6-1
 Lubrication Chart6-5
 Lubrication Points6-5
 Lubrication Symbols6-1

ALPHABETICAL INDEX (continued)

M and N

	Page
Maintenance Instructions	6-1
Major Components and Systems	4-1
Normal Engine Starting	5-23
Notes for Lifting Capacities	E-3

O

Operating Cab Heater	5-35
Operating Procedures	5-23
Operator's Seat Controls	5-6
Operator Troubleshooting Table	6-13
Outrigger Control Lever	5-7
Outrigger Float Pads, Proper Installation	5-12
Outrigger Selector Switch (Right and Left Side)	5-7
Outrigger System	4-3

P, Q

Panel Lamp	5-5
Park Brake Indicator	5-8
Park Brake Lever	5-7
Personnel Platforms	2-23
PMCS Chart	5-12
Preliminary Servicing and Adjustment	3-1
Preparation for Use	3-1
Preventive Maintenance Checks and Services (PMCS)	5-8
Principles of Operation	4-1

R

Raising the Hoist Cable	5-34
Recommended Crane Shutdown Procedures	5-34
References	A-1
Reporting Errors	i
Retracting the Boom	5-33

S

Safety Precautions	2-1
Seat Belt, Inspection	5-17
Setting the Outriggers	5-30
Shutdown Procedure	5-24
Spotlight	5-6
Steering System	4-2

ALPHABETICAL INDEX (continued)

S (continued)

	Page
Stowing the Outriggers	5-30
Summary	3-1
Swing Brake, Check for Proper Operation	5-20
Swing Control Lever	5-7
Swinging the Boom	5-31
Swivels	4-3
Symptom Index	6-12

T

Telescope Control Lever	5-7
Terms to Know When Using Load Chart	5-28
Tire Inflation Chart	E-10
Tire Pressures	E-10
Tires, Inspect for Wear	5-12
Transmission Control Lever (1-2-D-N-R)	5-7
Transmission, Fluid Level Check	5-14
Transportation and Lifting Decal	1-6
Travel Operation	2-7
Troubleshooting	6-12
Turn Signal/Four-Way Flasher	5-2
Turntable Assembly and Swing Mechanism	4-3
Two-block Indicator	5-8
Two-block Lockout Override	5-8

U

Unpacking	3-1
Using Load Chart	5-28

V

Voltmeter	5-2
-----------------	-----

W, X, Y, Z

	Page
Windshield Washer Bottle Fluid Level Check	5-17
Windshield Wiper/Washer Switch	5-5
Wire Rope, Inspection	5-16
Wire Rope and Sheaves	2-13
Wire Rope Lubrication	6-10

By Order of the Secretary of the Army:

DENNIS J. REIMER
General, United States Army
Chief of Staff

Official:

JOEL B. HUDSON
Administrative Assistant to the
Secretary of the Army
03702

DISTRIBUTION:

To be distributed in accordance with the initial distribution number (IDN) 256445 requirements for TM 10-3950-672-10.

RECOMMENDED CHANGES TO EQUIPMENT TECHNICAL PUBLICATIONS



THEN...JOT DOWN THE
DOPE ABOUT IT ON THIS FORM.
CAREFULLY TEAR IT OUT, FOLD IT
AND DROP IT IN THE MAIL.

SOMETHING WRONG WITH PUBLICATION

FROM: (PRINT YOUR UNIT'S COMPLETE ADDRESS)

DATE SENT

PUBLICATION NUMBER

PUBLICATION DATE

PUBLICATION TITLE

BE EXACT PIN-POINT WHERE IT IS

PAGE
NO.

PARA-
GRAPH

FIGURE
NO.

TABLE
NO.

IN THIS SPACE, TELL WHAT IS WRONG
AND WHAT SHOULD BE DONE ABOUT IT.

TEAR ALONG PERFORATED LINE

PRINTED NAME, GRADE OR TITLE AND TELEPHONE NUMBER

SIGN HERE

